

WTM
(Weight Transmitter)
Manual

LAST Rev. NO : 1 (9040-WTM-0033-1)

LAST Rev. Date : 2017.02.07

Table of Contents

1. Cautions for Your Safety.....	3
2. User Warning.....	6
3. RECOMMENDATIONS FOR CORRECT INSTALLATION OF THE LOAD CELLS.....	7
4. Features.....	10
5. Overview.....	12
6. External Dimension.....	13
7. Installation & Connection.....	15
8. Weight Setup (Calibration) Mode.....	16
9. How to Seal the Indicator (Sealing).....	25
10. Weighing Mode.....	26
11. Test mode.....	28
12. Set Mode.....	32
13. Appendix.....	57
14. MODBUS-RTU PROTOCOL.....	64
15. Error Message.....	70

1 Cautions for Your Safety

‘ Please comply with 'Cautions for Your Safety', which will lead you to use the product safely and properly to prevent any dangerous situations.

- Cautions are divided into 'Warning' and 'Alert', which mean as follows.
- Keep this manual in a place where product users can find out, after finish reading it.



Warning

'Warning' means a great possibility led to the death or heavy injury when instructions are violated.



Attention

'Alert' means a great possibility led to the injury or material damage when instructions are violated.

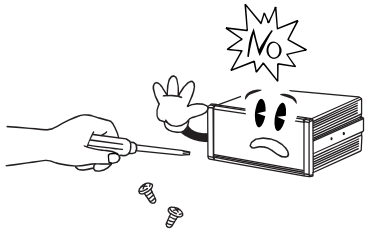
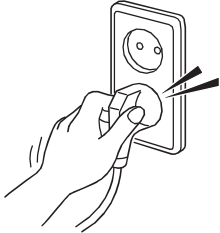
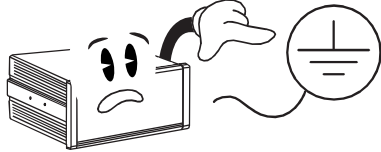
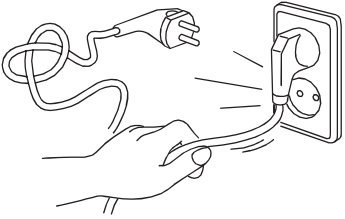
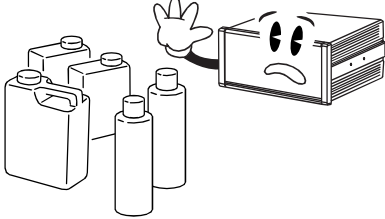
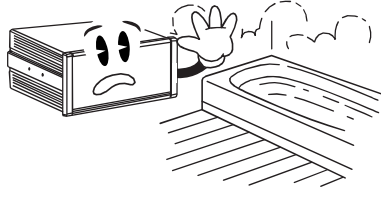
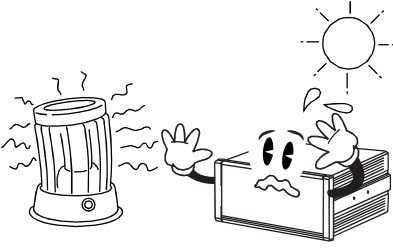

WTM User Manual - Rev.1

⚠ Warning

<p>Never disassemble, repair or retrofit the product. It might exclude the product from the quality assurance and cause the damage to devices, electric shock or fire.</p>	<p>Ensure the power plug to be fully inserted to prevent shaking. Any instable connection might cause electric sparks to set fire.</p>	<p>Ensure the grounding of the product. Poor grounding might cause failure or electric shock upon electric leak.</p>
		
<p>Do not damage, process, excessively jerk, bend or twist the power cord. It might damage the power cord to cause fire or electric shock.</p>	<p>Keep any combustible spray or fire source away. It might cause fire.</p>	<p>Do not spray water to the outside of the product or use it in any humid place. It might deteriorate the insulation of electric parts that can cause the electric shock, fire risk or weighing errors.</p>
		
<p>Do not place the product to the direct sunlight or near any hot object like a heater. It might cause fire.</p>		
		

WTM User Manual - Rev.1

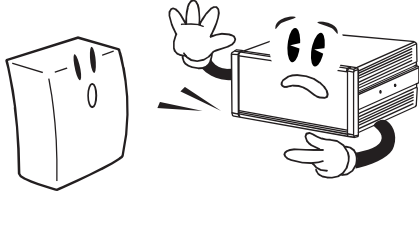
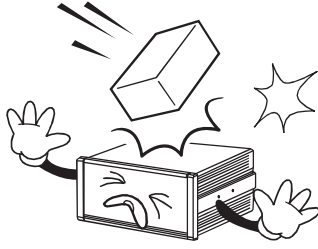
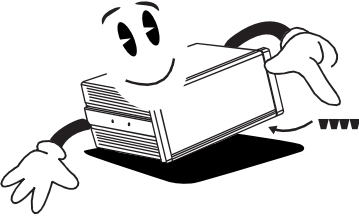
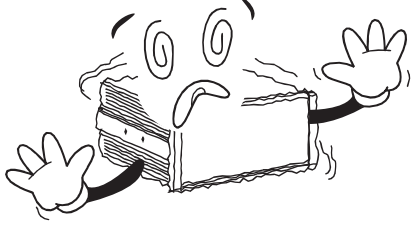
⚠ Attention

<p>Check the weighing error anytime for the accurate weighing. Any use out of the allowed tolerance for the careless use or other causes might not ensure the accurate weighing.</p>	<p>Avoid any sudden shock to the product. It might damage the product to fail the accurate weighing.</p>	<p>Find a proper place to attach the rubber pad at the bottom of the indicator, which was shipped together.</p>
		
<p>Do not use the product at a place with sudden temperature changes or severe vibrations. It might cause the weighing error or failure.</p>	<p>Do not install the produce at a place with the excessive electromagnetic wave. It might cause the wrong weighing.</p>	
		

Our Dealers : CAS feels that each of its valued customers should get the best service available. Whether it's the initial installation of our product, maintenance/repair work, or simply answering questions about our products, CAS Corporation and all of its Authorized Dealers are highly trained to assist you with any need regarding CAS products.

2 User Warning

Recommendations for the proper use of weighing instruments

- Keep away from heat sources and direct sunlight
- Repair the instrument from rain(except special IP versions)
- Do not wash with water jet(except special IP versions)
- Do not dip in water
- Do not spill liquid on the instrument
- Do not use solvents to clean the instrument
- Do not install in areas subject to explosion hazard(except special Atex versions)

Recommendations for correct installation of weighing instruments

The terminals indicated on the instrument's wiring diagram to be connected to earth must have the same potential as the weighed structure (same earthing pit or earthing system). If you are unable to ensure this condition, connect with an earthing wire the terminals of the instrument (including the terminal 0VDC) to the weighed structure.

The cell cable must be individually led to its panel input and not share a conduit with other cables; connect it directly to the instrument terminal strip without breaking its route with support terminal strips.

Use "RC" filters on the instrument-driven solenoid valve and remote control switch coils.

Avoid inverters in the instrument panel; if inevitable, use special filters for the inverters and separate them with sheet metal partitions.

The panel installer must provide electric protections for the instruments (fuses, door lock switch etc.).

It is advisable to leave the equipment always switched on to prevent the formation of condensation.

MAXIMUM CABLE LENGTHS

- RS485: 1000 metres with AWG24, shielded and twisted cables
- RS232: 15 metres for baud rates up to 19200

3 RECOMMENDATIONS FOR CORRECT INSTALLATION OF THE LOAD CELLS

INSTALLING LOAD CELLS: The load cells must be placed on rigid, stable in-line structures; it is important to use the mounting modules for load cells to compensate for misalignment of the support surfaces.

PROTECTION OF THE CELL CABLE: Use water-proof sheaths and joints in order to protect the cables of the cells.

MECHANICAL RESTRAINTS (pipes, etc.): When pipes are present, we recommend the use of hoses and flexible couplings with open mouthpieces with rubber protection; in case of hard pipes, place the pipe support or anchor bracket as far as possible from the weighed structure (at a distance at least 40 times the diameter of the pipe).

CONNECTING SEVERAL CELLS IN PARALLEL: Connect several cells in parallel by using – if necessary - a watertight junction box with terminal box. The cell connection extension cables must be shielded, led individually into their piping or conduit and laid as far as possible from the power cables (in case of 4-wire connections, use cables with 4 x 1 sq.mm minimum cross-section).

WELDING: Avoid welding with the load cells already installed. If this cannot be avoided, place the welder ground clamp close to the required welding point to prevent sending current through the load cell body.

WINDY CONDITIONS - KNOCKS - VIBRATIONS: The use of weigh modules is strongly recommended for all load cells to compensate for misalignment of the support surfaces. The system designer must ensure that the plant is protected against lateral shifting and tipping relating to: shocks and vibration; windy conditions; seismic conditions in the installation setting; stability of the support structure.

EARTHING THE WEIGHED STRUCTURE: By means of a copper wire with suitable cross-section, connect the cell upper support plate with the lower support plate, then connect all the lower plates to a single earthing system. Electrostatic charges accumulated because of the product rubbing against the pipes and the weighed container walls are discharged to the ground without going through or damaging the load cells. Failure to implement a proper earthing system might not affect the operation of the weighing system; this, however, does not rule out the possibility that the cells and connected instrument may become damaged in the future. It is forbidden to ensure earthing system continuity by using metal parts contained in the weighed structure.

**FAILURE TO FOLLOW THE INSTALLATION RECOMMENDATIONS
WILL BE CONSIDERED A MISUSE OF THE EQUIPMENT**

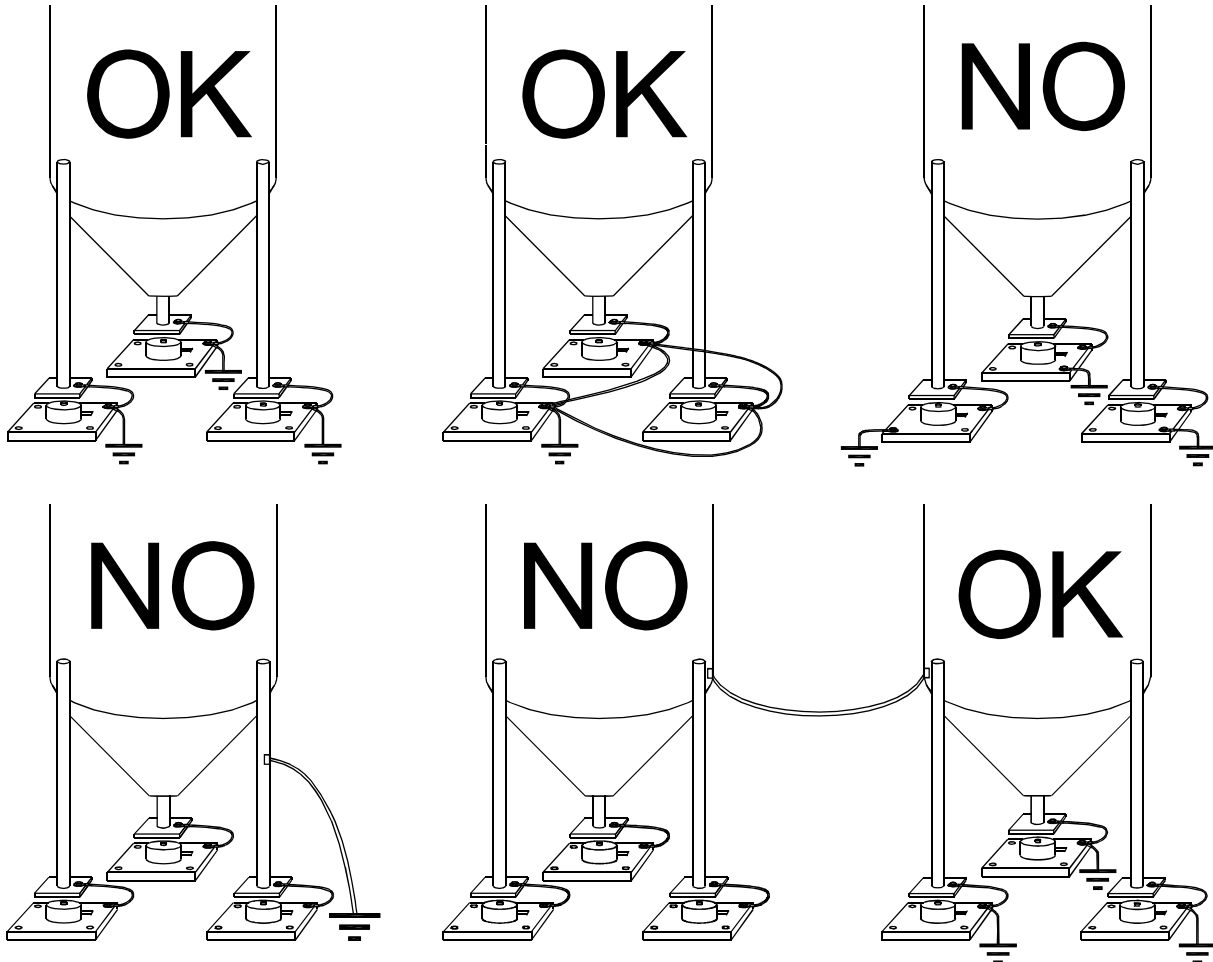

LOAD CELL TESTING

Load cell resistance measurement (use a digital multimeter):

- Disconnect the load cells from the instrument and check that there is no moisture in the cell junction box caused by condensation or water infiltration. If so, drain the system or replace it if necessary.
- The value between the positive signal wire and the negative signal wire must be equal or similar to the one indicated in the load cell data sheet (output resistance).
- The value between the positive excitation wire and the negative excitation wire must be equal or similar to the one indicated in the load cell data sheet (input resistance).
- The insulation value between the shield and any other cell wire and between any other cell wire and the body of the load cell must be higher than 20 Mohm (mega ohms).

Load cell voltage measurement (use a digital multimeter):

- Take out the load cell to be tested from underneath the container, or alternatively, lift the container support.
- Make sure that the excitation of two wires of the load cell connected to the instrument (or amplifier) is 5 Vdc +/- 3%.
- Measure the response signal between the positive and the negative signal wires by directly connecting them to the tester, and make sure that it is comprised between 0 and 0.5 mV (thousandths of a Volt).
- Apply load to the cell and make sure that there is a signal increment.

IF ONE OF THE ABOVE CONDITIONS IS NOT MET, PLEASE CONTACT THE TECHNICAL ASSISTANCE SERVICE.

WTM User Manual - Rev.1

4 Features

Power supply		Unit
Power supply voltage	10 ~ 24	V
Max consumption	70 with 350 Ω	mA
Temperature range		
Storage temperature	-25 ~ 85	$^{\circ}\text{C}$
Operating temperature	-10 ~ 40	$^{\circ}\text{C}$
Loadcell		
Impedance(complete bridge)	> 80	Ω
Connection	4 or 6 wires	
Loadcell power supply	5 \pm 5 %	Vdc
Communication		
RS485	Half duplex	
Baud rate	9600 ~ 115200	BPS
Logical inputs		
Numbers	2	
type	Optocoupler	
Low level voltage	0 ~ 3	Vdc
Higi level voltage	9 ~ 24	Vdc
Current at high level	10 mA @ 24 V	mA
Insulation voltage	2500	Vrms
Logical outputs		
Numbers	4	
type		
Max current @ 40 $^{\circ}\text{C}$		
Max voltage in open state	2	Ω
Insulation voltage	2500	Vrms
Legal for use metrological characteristics		
Class	III or IIII	

WTM User Manual - Rev.1

Minimum voltage division per verification scale division	0.5	uV
Maximum voltage for weighing range	39	mV
Programmable functions		
Acquisition of zero, taring, zero tracking		
Physical or theoretical calibration		
Slope correction		
Non-linearity polynomial correction		
Low pass, band-stop and self-adaptive digital filters		
Set points managements		
Checkweigher functioning mode		
Peak detection functioning mode		
Option		
Display	7 Segment LED, 4 key	
A-Out	V-out, I-out	-10 V~10 V 0~24 mA
Relay I/O	2input, 4output	
Alibi memory	50,000] Save Real time clock	
Ethernet	10/100 M	
Fieldbus	Profibus	

* You can download WTM software at the CAS homepage. (<http://www.globalcas.com/>)

Overview

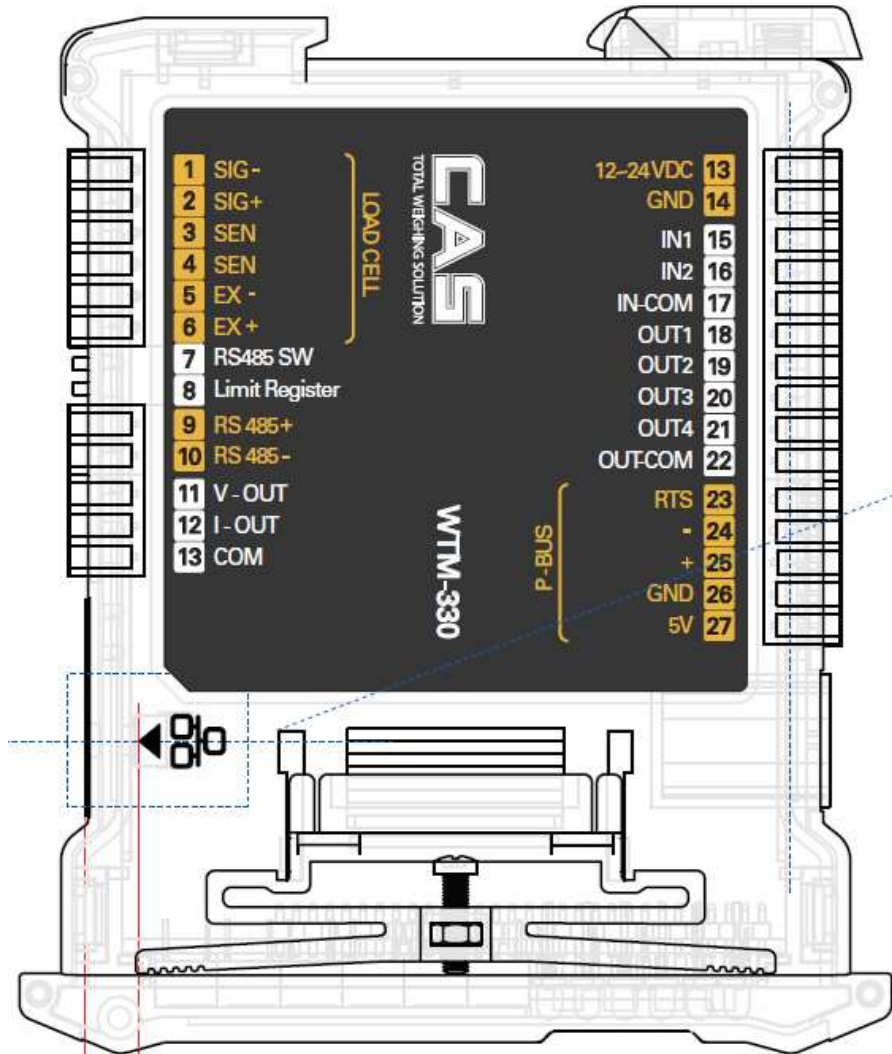

5 External Dimension

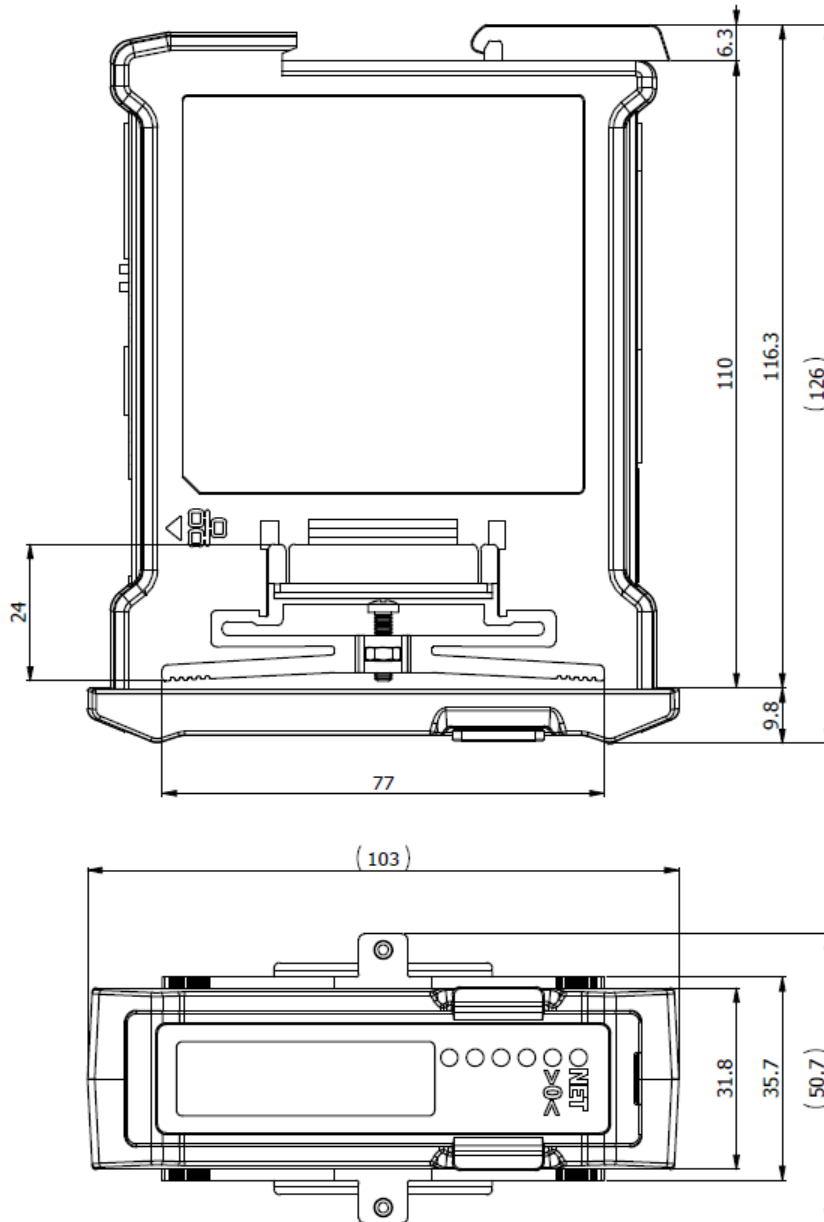

1. Weight : 6Digits, Decimal point, sign
2. Unit : ton, kg, lb
3. Message : Displayed of indicator's status





Ext Output are 4
Ext Inputs are 2

WTM User Manual - Rev.1

■ Display

LED	Main function (F5-05 OFF Set)	Sub function (F5-05 ON Set)
NET	On = Net , Off = Gross	LED ON : output 4 Closed
→0←	Zero LED	LED ON : output 3 Closed
	Stable LED	LED ON : output 2 Closed
t	Unit : ton	LED ON : output 1 Closed
kg	Unit : kg	LED ON : input 2 Closed
L	Unit : lb	LED ON : input 1 Closed

■ Key function

	ESC	* It sets the weight display near zero point to 0. (A range of 2%, 5%, 10%, 20% and 100% can be selected.)
	LEFT	* Use it change to item number
	HI	* Some functions can be defined to the needs.
	ENTER	* Use it enter to menu mode.

6 Installation & Connection

1. Loadcell Connection

Connect the loadcell cable to the terminal block of WTM

<6wires loadcell>

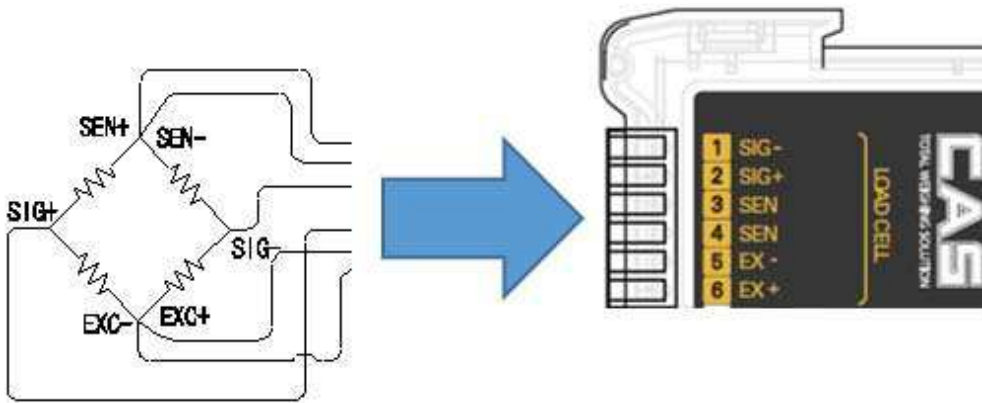

Note 1. In case of 4 wires load cell, connect EX+ with SEN+, and connect EX- with SEN-.

Note 2. Max 8 loadcells can connect to WTM (when loadcell impedance 350 Ω)

* Relationship between the load cell output and input sensitivity.

The input sensitivity of this product is maximum 0.2uV/digit or more.

The following equation should be satisfied upon the system design.

$$0.2\mu\text{V} \leq \frac{\text{Applied voltage of load cell} \times \text{Output voltage of load cell} \times \text{Value of a division}}{\text{Rated capacity of load cell} \times \text{Number of load cell}}$$

Example 1) Number of load cell: 4 ea

Rated capacity of load cell: 500 Kg

Rated output of load cell: 2mV/V

Value of a division: 0.10 Kg

Applied voltage of load cell: 5V (= 10,000 mV)

According to the equation → $(10000 \text{ mV} \times 2\text{mV} \times 0.1\text{Kg}) / (500\text{Kg} \times 4) = 1 \geq 0.3\mu\text{V}$

As the calculated value is greater than 0.3uV, this weight system design has no problem.

Note 3. It can check the mV/V value in the testmode3

7 Weight Setup (Calibration) Mode

What is the weight setup?

It refers to the calibration to set the displayed value to the actual weight in displaying weights.

How to Access to the Weight Setup Mode

Turn on the power supply to access to the weight setup mode while pressing Cal S/W after removing the sealing

Calibration Menu (CAL1 – CAL9)

- CAL 1: Maximum capacity
- CAL 2: Minimum division and decimal position setting
- CAL 3: Zero & Span calibration
- CAL 4: Hopper calibration
- CAL 5: Direct calibration
- CAL 6: Zero adjustment
- CAL 7: Factor calibration
- CAL 8: Gravity adjustment
- CAL 9: Setting dual range

WTM User Manual - Rev.1

CAL 1 (CAL 1 automatically starts.)

CAL 1-1

Function : Set Range Set Unit : kg, lb, ton		
Used key	Display	Descriptions
▲ : Value increase ✕ : Cancele ← : Save and next Menu	kg	Kilogram (kg)
	lb	poiund (lb)
	ton	ton

CAL 1-2

Function: Setting Maximum Value Range of set value: 1 ~ 99,999		
Used key	Display	Descriptions
▲ : Value increase ◀ : Digit change ✕ : Cancele ← : Save and next Menu	C= 10000	Max value = 10000 kg
	C= 10	Max value = 10 kg

Note 1. It means the maximum weight value to be weighed by the scale.

CAL 2

Function: Minimum division and decimal position setting

Range of set value: 0.001 ~ 50

Used key	Display	Descriptions
▲ : Value increase ✕ : Cancele ⬅ : Save and next Menu	d= 0.001	Minimum division 0.001 kg
	d= 0.01	Minimum division 0.01 kg
	d= 0.1	Minimum division 0.1 kg
	d= 1	Minimum division 1 kg
	d= 10	Minimum division 10 kg

Note 1. To end CAL2, press CANCEL key when a decimal point is set.

Note 3. Set the external resolution within 1/30,000 as the value by dividing the maximum weight by the minimum division.

If the external resolution is 1/30,000 or more, Err 21 is shown.

Note 4. The position of a decimal point is decided by the position of a decimal point for the minimum division set in CAL2.

CAL 3

CAL 3-1

Function: Setting Multi Calibration Step		
Range of set value: 1 ~ 5		
Used key	Display	Descriptions
▲ : Value increase ✕ : Cancele ← : Save and next Menu	STEP- 1	Setting multi calibration for step 1 (CAL3-3 and CAL 3-4 are carried out once)
	STEP- 5	Setting multi calibration for step 5 (CAL3-3 and CAL 3-4 are carried out five times.)

* A function to use, when the output of load cell is corrected by setting multiple points in some sections because the actual curve of load cell is not a straight line.

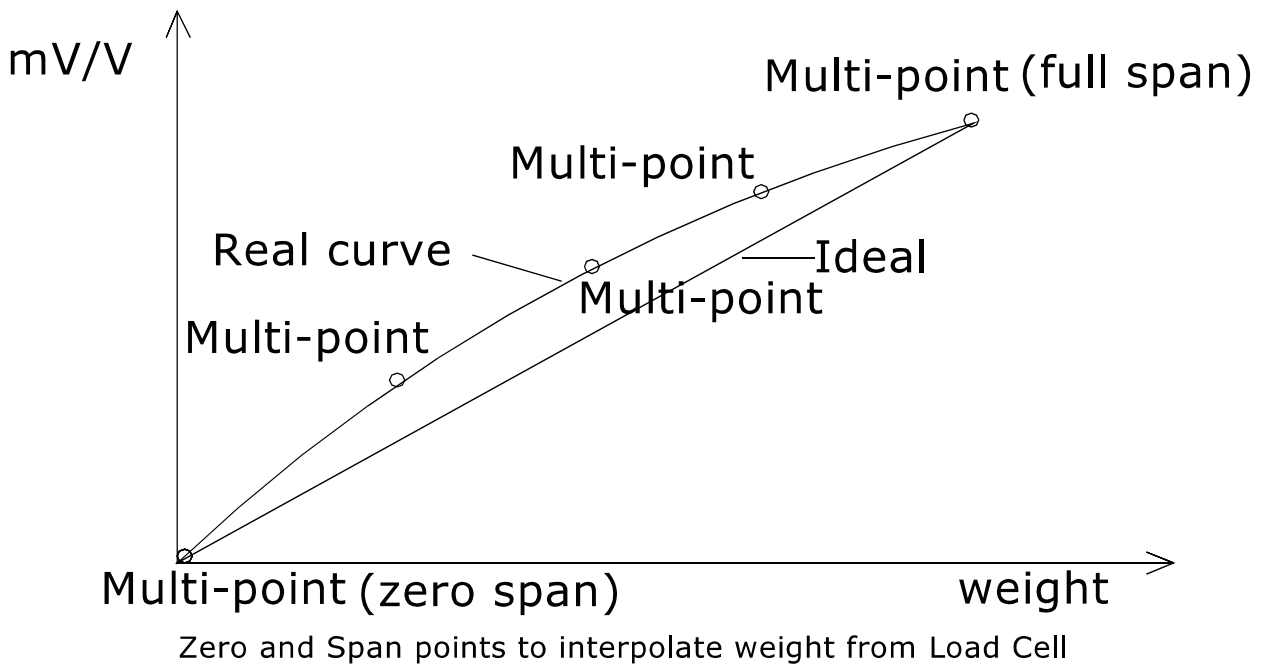

WTM User Manual - Rev.1

CAL 3-2

Function: Zero Calibration		
Used key	Display	Descriptions
× : Cancele ← : Save and next Menu	UnLoAd	Empty the load tray and press the setup key.
	1234	The current weight value is displayed. Confirm 'Stable' and press the setup key.
	- - -	Zeroing in progress...

Note 1. If zeroing finished with no error, it moves to Setting Weight (CAL 3-3) although no key is pressed.

CAL 3-3

Function: Setting Weight Range of set value: 1 ~ 99,999		
Used key	Display	Descriptions
▲ : Value increase ◀ : Digit change × : Cancele ← : Save and next Menu	LOAD 1	It means the weight setting mode. (Number = multi calibration number)
	W=100.00	100.00 (unit: Kg or Ton)
	W= 0.10	0.10 (unit: Kg or Ton)

Note 1. Set the weight within a range of 10% ~ 100%.

CAL 3-4

Function: Weight Calibration		
Used key	Display	Descriptions
× : Cancele ← : Save and next Menu	LoAd	Load the weight set in CAL 4-3 and press the setup key.
	12345	The current weight value is displayed. Confirm 'Stable' and press the setup key.
	- - -	Span adjustment in progress...

Note 1. CAL 3-3 and CAL 3-4 are repeated as many as STEP is set in CAL 3-1.

At this time, the weight value should be set to a value greater than the previous one.

Note 2. Move to CAL-1 if the span adjustment is over with no error.

WTM User Manual - Rev.1

CAL 4(Hopper Calibration)

CAL 4-1

Function: Setting Multi Calibration Step		
Range of set value: 2 ~ 5		
Used key	Display	Descriptions
▲ : Value increase ✕ : Cancele ← : Save and next Menu	STEP- 2	Setting multi calibration for step 2 (for hopper system)
	STEP- 5	Setting multi calibration for step 5 (for hopper system)

CAL 4-2

Function: Setting Weight		
Range of set value: 1 ~ 99,999		
Used key	Display	Descriptions
▲ : Value increase ◀ : Digit change ✕ : Cancele ← : Save and next Menu	LOAD 1	It means the weight setting mode. (Number = multi calibration number)
	W=100.00	100.00 (unit: Kg or Ton)
	W= 0.10	0.10 (unit: Kg or Ton)

Note 1. Set the weight within a range of 10% ~ 100%

CAL 4-3

Function: Weight Calibration		
Used key	Display	Descriptions
✕ : Cancel ← : Save and next Menu	LoAd	Load the weight set in CAL 4-3 and press the setup key.
	12345	The current weight value is displayed. Confirm 'Stable' and press the setup key.
	- - -	Span adjustment in progress...

Note 1. CAL 4-2 and CAL 4-3 are repeated as many as STEP is set in CAL 4-1.

At this time, the weight value should be set to a value greater than the previous one.

Note 2. Move to CAL-1 if the span adjustment is over with no error.

CAL 5(Direct Calibration)

CAL 5-1

Function: Direct input about the zero value of loadcell		
Range of set value: 1 ~ 99,999		
Used key	Display	Descriptions
▲ : Value increase ◀ : Digit change ✕ : Cancel ⬅ : Save and next Menu	ZE-CAL	Direct zero input mode
	0.0000	Loadcell zero = 0.0000 mV/V
	0.1000	Loadcell zero = 0.1000 mV/V

CAL 5-2

Function: Direct input about the span value of loadcell		
Range of set value: 1 ~ 99,999		
Used key	Display	Descriptions
▲ : Value increase ◀ : Digit change ✕ : Cancel ⬅ : Save and next Menu	SP-CAL	Direct span input mode
	1.2000	Loadcell span = 1.2000 mV/V
	2.0000	Loadcell span = 2.0000 mV/V

CAL 6

Function: Zero adjustment - calibration when any zeroing error occurs.		
Used key	Display	Descriptions
✕ : Cancel ⬅ : Save and next Menu	2-CAL	Empty the load tray and press the setup key.
	1234	The current weight value is displayed. Confirm 'Stable' and press the setup key.
	- - -	Zero adjustment in progress...

Note 1. Use this function when zeroing is not passed for any shock to the load cell.

The range of zero adjustment is 0 ~ 2mV/V.

Note 2. Move to CAL-1 if the zero adjustment is over with no error.

WTM User Manual - Rev.1

CAL 7

Function: Factor Calibration		
Used key	Display	Descriptions
▲ : Value increase ◀ : Digit change ✕ : Cancel ⬅ : Save and next Menu	NOTUSE FACtor 12345	This function cannot be used because of multi calibration. It means you entered the factor correction mode. The current factor is displayed.

Note 1. As this is a menu to set the weight setup with no weight, general users have no need to use it.

Note 2. This can be used only when the range of multi calibration in CAL 3-1 is set to 1.

"NOT USE" is displayed when the range of CAL 3-1 is set to 2 or larger.

Note 3. Enter a password to enter the factor correction mode.

CAL 8

Function: Gravity Adjustment		
Used key	Display	Descriptions
▲ : Value increase ◀ : Digit change ✕ : Cancel ⬅ : Save and next Menu	G-CAL Gr-CAL 9.XXXX Gr-SET 9.XXXX	It means you accessed to the menu for the gravity adjustment. Set the gravity for the production place. Set the gravity for the place to use the product.

Note 1. If the gravity of the indicator production place is different from that of the place to use, the gravity adjustment can be done using this function.

CAL 9

CAL 9-1

Function: Setting Dual Range Range of set value: 0 ~ 1		
Used key	Display	Descriptions
▲ : Value increase ✕ : Cancel ⬅ : Save and next Menu	DUAL- 0	Dual range function is not used.
▲ : Value increase ◀ : Digit change ✕ : Cancel ⬅ : Save and next Menu	DUAL- 1	Dual range function is used.

Note 1. If the resolution capability is 1/10,000 or higher, "OVER" message is displayed and return to the CAL menu mode.

CAL 9-2

Function: Setting the applied section for the Dual Range Range of set value: 0 ~ 99999		
Used key	Display	Descriptions
▲ : Value increase ◀ : Digit change ✕ : Cancel ⬅ : Save and next Menu	M 1000	Dual range is applied to less than 1000kg.
▲ : Value increase ◀ : Digit change ✕ : Cancel ⬅ : Save and next Menu	M 5000	Dual range is applied to less than 5,000kg.
▲ : Value increase ◀ : Digit change ✕ : Cancel ⬅ : Save and next Menu	M 10000	Dual range is applied to less than 10,000kg.

Note 1. If the input value is greater than the maximum value, "ERR SET" message is displayed and returned to the CAL menu mode.

8 How to Seal the Indicator (Sealing)

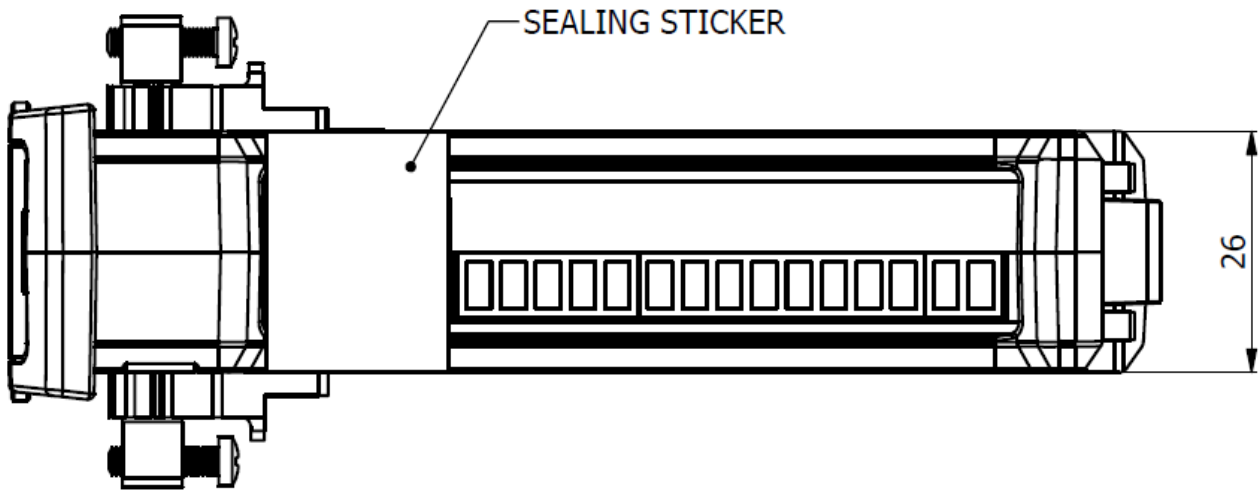

9 Weighing Mode

* Zero function

- Zero range : It is depend on set value of F1.09

	Display Part or Used Keys	Load Plate	Description
Step 1	0.100	Empty	State with zero changed
Step 2	×		Push the zero key
Step 3	0.000	Empty	State after performing zero function. Namely, the current weight is designated as '0'kg.

Note 1. Operating range for the zero key is possible between $\pm 1\%$ ~ $\pm 99\%$ of the maximum weight. Operating range for the zero key is designated in Menu No. [2-1-16].

Note 2. Menu No. [2-1-14] designates whether to perform zero function only if the current weight is stabilized or even when it is unstable.

* Tare function

- Tare range : It is depend on set value of F1.10

	Display Part or Used Keys	Load Plate	Description
Step 1	1.000	Tare Placement	State with tare placed on load plate Weight plate : 1.000 kg
Step 2	▲		Push the tare key
Step 3	0.000	Tare	State with NET lamp turned ON and tare registered

Note 1. It function is enabled, when F1 key is set to Tare key

WTM User Manual - Rev.1

* Item number changing

	Display Part or Used Keys	Load Plate	Description
Step 1	◀	-	Press F1 key (If F1 key is Item code key..)
Step 2	Id - 01	-	Item Code = 1
Step 3	◀, ▲	-	Change the item number.
Step 4	↩	-	Item number is saved

Note 1. It function is enabled, when F1 key is set to Tare key

* Set point changing

	Display Part or Used Keys	Load Plate	Description
Step 1	▲	-	Press the ▲ key
Step 2	SP-1	-	Displayed current setpoint number
Step 3	01.000		Change the set point value
	◀, ▲		
Step 4	↩	-	Set point is saved
Step 5			Repeat setp1~3 until end point of max set point

Note 1. It function is enabled, when F1 key is set to Tare key

10 Test mode

How to Enter the Test Mode

While power on, press the **X** key, then move to test mode
Or in weighing mode, press the **←** key, displayed '1.test' .
Press the **←** key, move to set mode

Press the **X** key in the set mode to return to weighing mode.

TEST Menu (1 – 9)

1. Key Test
2. LCD Test
3. AD Test
4. Communication Test(COM1, COM2)
5. External Input/output Test
7. A-out Option test
8. EEPROM test
9. RTC test

WTM User Manual - Rev.1

TEST 1

Function: Key test		
Used key	Display	Descriptions
⏪ : Next Menu Other keys : Test	KEY 01	When you press any key to test, the number and code for the key are displayed on the screen.

1.1 Key List

Key	Code	Key	Code	Key	Code	Key	Code
✕	27	⏪	60	⏴	62	⏩	30

TEST 2

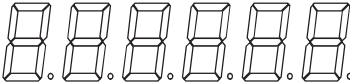
Function: Display Screen Test		
Used key	Display	Descriptions
✕ : Cancel ⏪ : Next Menu		All LED lamp is on.

TEST 3

Function: Load cell test and A/D conversion test		
Used key	Display	Descriptions
✕ : Cancel ⏪ : Next Menu	XXXXXXX	The internal value for the current weight value is displayed.

TEST 4

Function: Serial Communication Test		
Used key	Display	Descriptions
▲ : Value change	Tx -- Rx	Status to wait for transmission or reception Transmission: 2, Reception: 13
✕ : Cancel	-----	
← : Next Menu	02 -04	

Note 1. Run this test while the communication program in the computer

(ex: Hyper Terminal) is executing after connecting a serial port in the computer to the serial port on the back.

Note 2. Send '1' from the computer keyboard, check whether or not '1' is received properly on the indicator's screen, and then check whether or not '1' is received properly on the computer after pressing '1' from the indicator's keyboard.

TEST 5

Function : External Input / Output Test		
Used key	Display	Descriptions
▲ : Value change	I - X O - X	Displayed in the external input section when there is an external input. Push ▲ key to execute weighing external output input : 2, output : 4
✕ : Cancel	-----	
← : Next Menu	I - 2 O - 4	

Note 1. This test operates only if Ext IO Option Card is mounted

TEST 6

Function : A-Out Test		
Used key	Display	Descriptions
▲ : Value change	25 P	The output level of Aout is raised by 25% each time the ▲ key is pushed.
✕ : Cancel		
← : Next Menu		

Note 1. This test operates only if Analog out Option Card is mounted.

TEST 8

Function: EEPROM Test		
Used key	Display	Descriptions
← : Next Menu	ROM OK ROM NG	Display EEPROM status

TEST 9

Function: RTC Test		
Used key	Display	Descriptions
← : Next Menu	SEC XX	XX : Displaying the progress of seconds (SEC)

Note 1. If alibi memoy is not mounted, this mode is closed

11 Set Mode

How to Enter the Set Mode

While power on, press the ◀ key, then move to set mode

Or in weighing mode, press the ← key, displayed '1.test'.

Press the ▲ key, then displayed '2.set' and press the ← key, move to set mode

Press the ✕ key in the set mode to return to weighing mode.

Classification	Menu	SubMenu
1. General Setting	F1.01	Set AD speed
	F1.02	Set Average filter buffer
	F1.03	Set Lowpass filter
	F1.04	Set Bandstop filter
	F1.06	Set stable range
	F1.07	Set Automatic Zero Tracking Compensation
	F1.08	Set Weight Back-up
	F1.09	Set Zero range
	F1.10	Set Tare range
	F1.11	Set Init Zero
	F1.12	Set Weighing Unit
	F1.13	Set F1 Key Use Type
	F1.14	Set Hold Type
	F1.15	Set Average Hold time
	F1.16	Set Hold Canceling Conditions
	F1.17	Set Automatic Hold Starting Conditions
	F1.18	Set Automatic Hold Canceling Conditions
	F1.19	Set Key Operating Conditions
	F1.20	Initializing of set values

WTM User Manual - Rev.1

Classification	Menu	SubMenu
2. Communication Setting	F2.01	Set Device ID
	F2.02	Set Data Transmission Rate
	F2.03	Set Com1 Port Setting
	F2.04	Set COM1 RS-232C Baud Rate
	F2.05	Set COM1 Out Data
	F2.06	Set COM1 Output Format
	F2.07	Set COM1 Output mode
3. A-Out Setting	F3.01	A-out Range
	F3.02	V-out Range
	F3.03	I-out Range
	F3.04	Dual output mode
	F3.05	Minimum weight of A-out
	F3.06	Maximum weight of A-out
	F3.07	Adjust zero of A-out
	F3.08	Adjust span of A-out
4. Device Setting	F4.01	Set Date
	F4.02	Set Time
	F4.03	Use Alibi memory
	F4.04	Memory over writing
5. Logic Setting	F5.01	Relay Out mode
	F5.02	Ext input 1
	F5.03	Ext input 2
	F5.04	Relay Reverse On/Off
	F5.05	Relay Display

WTM User Manual - Rev.1

Classification	Menu	SubMenu
5. TCP.IP	F6.01	Set DHCP
	F6.02	Set Server /Client
	F6.03	WTM's IP Server mode
	F6.04	Subnet Mask
	F6.05	Gate way
	F6.06	WTM's TCP Port Server mode
	F6.07	Comm type of Server mode
	F6.08	Set Client IP
	F6.09	Set Client's TCP Port
	F6.10	Comm type of Client mode

1. General Function

Menu-F1.01

Function	Set AD Speed	
Set Range (0~8)	Display Part	Meaning
	1-01. 0	Converting speed 5 times per second
	1-01. 1	Converting speed 10 times per second
	1-01. 2	Converting speed 20 times per second
	1-01. 3	Converting speed 40 times per second
	1-01. 4	Converting speed 100 times per second
	1-01. 5	Converting speed 160 times per second
	1-01. 6	Converting speed 320 times per second
	1-01. 7	Converting speed 800 times per second
	1-01. 8	Converting speed 1600 times per second

Menu-F1.02

Function	Set Digital Filter Buffer	
Set Range (1 ~ 50)	Display Part	Meaning
	1-02. XX Initial Value : 10	Setting the number of buffers in the digital filter

Note 1. Set it so as to be suite to the environment (Speed for weight changes may slow down)

WTM User Manual - Rev.1

Menu-F1.03: Set Low Pass Filter

Function	Low Pass Filter Setting	
	Display Part	Meaning
Set Range (0 ~ 1)	1-03 : XX Initial Value : 0	Low Pass Filter use setting. (0: Not use, 1: Use)
Set Range (2 ~ 4)	F-od.XX Initial Value : 2	Low Pass Filter Degree setting.
Set Range (1 ~ 1600)	C-FrEq Initial Value : 10	Low Pass Filter Frequency setting

Reference 1. Uses the LPF (Low Pass Filter). The LPF order and LPF frequency setting menus are only displayed in this mode.

Reference 2. When using LPF, set according to the environment.

Menu-F1.04: Set Band Stop Filter

Function	Band Stop Filter Setting	
	Display Part	Meaning
Set Range (0 ~ 1)	1-04 : XX Initial Value : 0	Band Stop Filter use setting. (0: Not use, 1: Use)
Set Range (1 ~ 1600)	H-FrEq Initial Value : 60	Band Stop Filter High Frequency setting..
Set Range (1 ~ 1600)	L-FrEq Initial Value : 10	Band Stop Filter Low Frequency setting..

Reference 1. Uses BSP (Band Stop Filter). The BSP High Frequency, BSP Low Frequency setting menus are only displayed in this mode.

Reference 2. When using BSP, set according to the environment.

Menu-F1.06

Function	Set Stable Range	
	Display Part	Meaning
Set Range (0 ~99)	○ x 0.5 division Initial Value: 1x 0.5 division	Stability lamp is turned ON when weight change is such that the width of change in a given time is within the set value x 0.5 division

Note 1. Function that acknowledges it as the stable state when the width of weight change within a set time does not exceed the set range X 0.5 division.

Note 2. Weighing stabilization will be made faster by setting the larger number if the environment involves much vibration in the surrounding and by setting the smaller number if there is little vibration.

WTM User Manual - Rev.1

Menu-F1.07

Function	Set Automatic Zero Tracking Compensation	
Set Range (0 ~ 99)	Display Part	Meaning
	1-07. XX Initial Value : 1x0.5Digit	Stability lamp is turned ON when weight change is such that the width of change in a given time is within the set value x 0.5 division

Note 1. This function automatically calibrates for zero if the weight does not exceed a given range of division within a given time in the zero state.

Ex) When the maximum display division is 120.0Kg with the value of one division set as 0.05Kg, provided that the Menu[2-1-07] is set as "2",

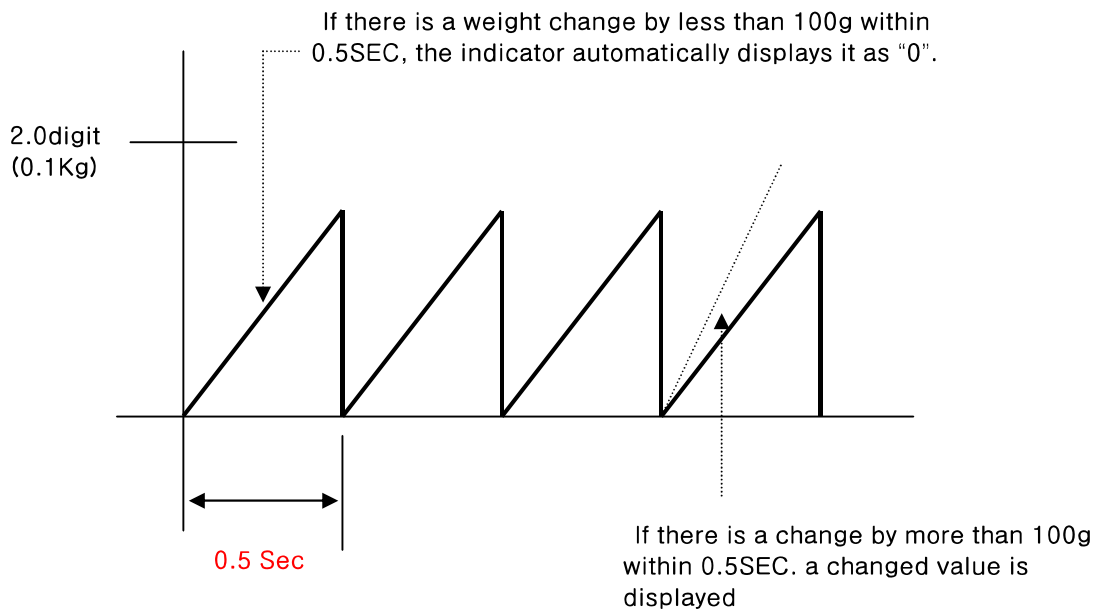

WTM User Manual - Rev.1

Menu-F1.08

Function	Set Weight Back-up	
Set Range (0, 1)	Display Part	Meaning
	1-08. 0	Weight back up function is not used
	1-08. 1	Weight back up is used (based on operation)

Menu-F1.09

Function	Set Zero Range	
Set Range (0 ~ 99)	Display Part	Meaning
	1-09. XX Initial Value : 10%	Zero operates up to within +/- 00% of the maximum weight

Menu-F1.10

Function	Set Tare Range	
Set Range (0 ~ 99)	Display Part	Meaning
	1-10. XX Initial Value : 99%	Tare operates up to within +/- 00% of the maximum weight

Menu-F1.11

Function	Set Initial Zero	
Set Range (0 ~ 99)	Display Part	Meaning
	1-11. XX Initial Value : 10%	Initial zero operates within +/- 00% of the Gross Weight

WTM User Manual - Rev.1

Menu-F1.12

Function	Set Weighing Unit	
Set Range (0 ~ 99)	Display Part	Meaning
	1-12. XX Initial Value : 9x0.5Digit	Overweight from the next to 0 x 1 Digit of the maximum weight

Menu-F1.13

Function	Set F1 Key Use Type	
Set Range (0 ~ 4)	Display Part	Meaning
	1-13.00	F1 Key used as the tare/tare cancelling key
	1-13.01	F1 Key used as the total/net whight key
	1-13.02	F1 Key used as the Hold key
	1-13.03	F1 Key used as the Holdless key
	1-13.04	F1 Key used as the Tare key

Menu-F1.14

Function	Set Hold Type	
Set Range (0 ~ 3)	Display Part	Meaning
	1-14.00	Average Value Hold
	1-14.01	Peak Hold
	1-14.02	Sampling Hold
	1-14.03	Automatic Hold

Menu-F1.15

Function	Average hold time	
Set Range (0 ~ 99)	Display Part	Meaning
	1-15. XX	Average value within the set value x sec is calculated

WTM User Manual - Rev.1

Menu-F1.16

Function	Set Hold Canceling Conditions	
	Display Part	Meaning
Set Range (0 ~ 2)	1-16.00	Hold is canceled when it becomes zero
	1-16.01	Hold is canceled when Hold key is entered
	1-16.02	Hold is canceled when Hold less key entered

Menu-F1.17

Function	Set Automatic Hold Starting Conditions	
	Display Part	Meaning
Set Range (0 ~ 99)		
	1-17. XX	Hold Starts when the weight changes within the set range value x 1 division

Menu-F1.18

Function	Set Automatic Hold Canceling Conditions	
	Display Part	Meaning
Set Range (0 ~ 99)		
	1-18. XX	Hold is canceled when the value is changed by more Than 00 % of the hold value

Menu-F1.19

Function	Set Key Operating Conditions(Zero, Tare)	
	Display Part	Meaning
Set Range (0, 1)		
	1-19. 0	Always in operation
	1-19. 1	Operates only if the weight is stable

WTM User Manual - Rev.1

Menu-F1.20

Function	Initializing of set values	
Set Range (0 ~ 1)	Display Part	Meaning
	Init- 0	No set values of the product are initialized to factory shipping state
	Init- 1	All set values of the product are initialized to factory shipping state

2. Communication Setting

Menu-F2.01

Function	Set Device ID	
Set Range (0 ~ 99)	Display Part	Meaning
	2-01. XX Initial Value : 0	Desired device ID may be entered.

Note 1 . This function may be used as the indicator's inherent ID in the COMMAND mode.

Menu-F2.02

Function	Set Data Transmission Rate	
Set Range (1 ~ 9999)	Display Part	Meaning
	XXXX Initial Value : 50x10ms	Data are transmitted by the unit of 00 x 10ms

Note 1. Data are transmitted in real time upon setting at“0”.

Menu-F2.03

Function	Set Parity Bit – RS232C & PRT	
Set Range (0 ~ 5)	Display Part	Meaning
	2-03. 0	Data Bit 8, Stop Bit 1, Parity Bit : None
	2-03. 1	Data Bit 7, Stop Bit 1, Parity Bit: Even
	2-03. 2	Data Bit 7, Stop Bit 1, Parity Bit: Odd
	2-03. 3	Data Bit 7, Stop Bit 2, Parity Bit: Odd
	2-03. 4	Data Bit 8, Stop Bit 1, Parity Bit: Even
	2-03. 5	Data Bit 8, Stop Bit 1, Parity Bit: Odd

WTM User Manual - Rev.1

Menu-F2.04

Function	Set COM1 RS-232C Baud Rate	
Set Range (0 ~ 7)	Display Part	Meaning
	2-04. 0	1,200 bps
	2-04. 1	2,400 bps
	2-04. 2	4,800 bps
	2-04. 3	9,600 bps
	2-04. 4	19,200 bps
	2-04. 5	38,400 bps
	2-04. 6	57,600 bps
	2-04. 7	115,200 bps

Menu-F2.05

Function	Set COM1 Out Data	
Set Range (0 ~ 2)	Display Part	Meaning
	2-05. 0	Displayed value is transmitted
	2-05. 1	Gross Weight is transmitted
	2-05. 2	Net weight is transmitted

Menu-F2.06

Function	Set COM1 Output Format	
Set Range (0 ~ 3)	Display Part	Meaning
	2-06. 0	22 byte of CAS
	2-06. 1	10 byte of CAS
	2-06. 2	18 byte Format(AND, FINE)
	2-06. 3	22 byte of CAS with relay status

Note 1. Note <Appendix 1> for communication format

WTM User Manual - Rev.1

Menu-F2.07

Function	Set COM1 Output mode(RS-485 - Output mode)	
	Display Part	Meaning
Set Range (0 ~ 8)	2-07. 0	Data is not transmitted
	2-07. 1	Transmitted only if the print key is pushed
	2-07. 2	Transmitted in both stable/unstable cases (Stream Mode)
	2-07. 3	Transmitted only if the weight is stable
	2-07. 4	Command Type 1
	2-07. 5	Command Type 2
	2-07. 6	Command Type 3
	2-07. 7	Transmitted only upon completion signal
	2-07. 8	Modbus protocol

Note 1. See Appendices 2, 3, 4 for command types

3. Analog Out Setting

Menu-F3.01

Function	Set A-Out range	
Set Range (0, 1)	Display Part	Meaning
	3-01. 0	Unipolar(operating in +weight)
	3-01. 1	Bipolar(operating in \pm weight)

Menu-F3.02

Function	V-out range	
Set Range (0 ~ 4)	Display Part	Meaning
	3-02. 0	V-out is closed
	3-02. 1	0 V~ 5 V
	3-02. 2	0 V~ 10 V
	3-02. 3	± 5 V
	3-02. 4	± 10 V

Note 1. If use only I-out , you have to set to 0

Menu-F3.03

Function	I-out range	
Set Range (0 ~ 3)	Display Part	Meaning
	3-03. 0	I-out is closed
	3-03. 1	4 mA ~ 20 mA
	3-03. 2	0 mA ~ 20 mA
	3-02. 3	0 mA ~ 24 mA

WTM User Manual - Rev.1

Menu-F3.04

Function	Dual output(V-out & I-out)	
Set Range (0, 1)	Display Part	Meaning
	3-04. 0	Dual output disabled
	3-04. 1	Dual output enabled

Menu-F3.05

Function	Minimum Output Weight Value upon Using Analog Out option	
Set Range (0 ~ 99999)	Display Part	Meaning
	1000	Maximum output at 1000 kg
	2000	Maximum output at 2000 kg

Menu-F3.06

Function	Maximum Output Weight Value upon Using Analog Out option	
Set Range (0 ~ 99999)	Display Part	Meaning
	1000	Maximum output at 1000 kg
	2000	Maximum output at 2000 kg

Menu-F3.07

Function	Adjust the Zero Output upon Using Analog Out option	
Set Range (0 ~ 99999)	Display Part	Meaning
	0000	0.000mA, 0V output
	4000	4.000mA, 2V output
	4015	4.015mA, 2.007V output

Note 1. Above example is to assume that the 0~10V, 0~24mA

Note 2. When use dual output mode(I-out, V-out), adjust function is disabled

WTM User Manual - Rev.1

Menu-F3.08

Function	Adjust the Maximum Output upon Using Analog Out option	
	Display Part	Meaning
Set Range (0 ~ 99999)	10000	10.000mA, 4.16V output
	20000	20.000mA, 8.33V output
	24000	24.000mA, 10.0V output

Note 1. Above example is to assume that the 0~10V, 0~24mA

Note 2. When use dual output mode(I-out, V-out), adjust function is disabled

4. Hardware Set Function

Menu-F4.01

Function	Set Date	
Direction Key : Data Designation	Display Part	Meaning
	10.08.17	August 17th, 2010

Menu-F4.02

Function	Set Time	
Direction Key : Data Designation	Display Part	Meaning
	11.30.10	30 minutes and 10seconds past 11 o'clock

Menu-F4.03

Function	Set Alibi memory	
Set Range (0, 1)	Display Part	Meaning
	4-04. 0	Alibi memory function is disable
	4-04. 1	Alibi memory function is enable

Menu-F4.04





Function	Set memory over writing	
Set Range (0, 1)	Display Part	Meaning
	4-05. 0	Disable over writing of memory
	4-05. 1	Enable over writing of memory

5. Relay Logic set

Menu-F5.01

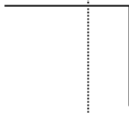
Function	Set Relay mode	
Set Range (0 ~ 3)	Display Part	Meaning
	5-01. 0	Limit Mode
	5-01. 1	Limit type Checker Mode
	5-01. 2	Checker Mode
	5-01. 3	Programmable Mode

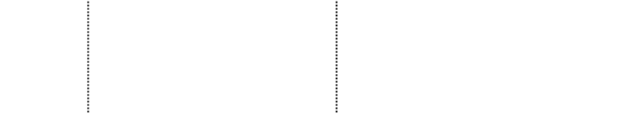
<Limit Mode>

Weight Output	(Low Limit) 50 pcs			(High Limit) 100 pcs	
	0 pcs				
Near Zero (Output1)					ON
					OFF
Low Limit (Output2)					ON
					OFF
High Limit (Output3)					ON
					OFF
Finish (Output4)					ON
					OFF

Note 1. 4th Relay is ON, when weight is stable and over than High limit value





WTM User Manual - Rev.1

<Limit type Checker Mode>

Weight Output	0 pcs	(Low Limit) 50 pcs	(High Limit) 100 pcs	
Near Zero (Output1)				ON OFF
Low Limit (Output2)				ON OFF
High Limit (Output3)				ON OFF
Finish (Output4)				ON OFF

WTM User Manual - Rev.1

<Checker Mode>

Weight Output	0 pcs	(Low Limit) 50 pcs	(High Limit) 100 pcs	
Near Zero (Output1)				ON
				OFF
Low Limit (Output2)				ON
				OFF
High Limit (Output3)				ON
				OFF
Finish (Output4)				ON
				OFF

Note 1. When weight is stable in the checker mode, relay output for the range the is operated
(the relay output will be fixed, until the weight is changed to 0)

WTM User Manual - Rev.1

< Programmable Mode >

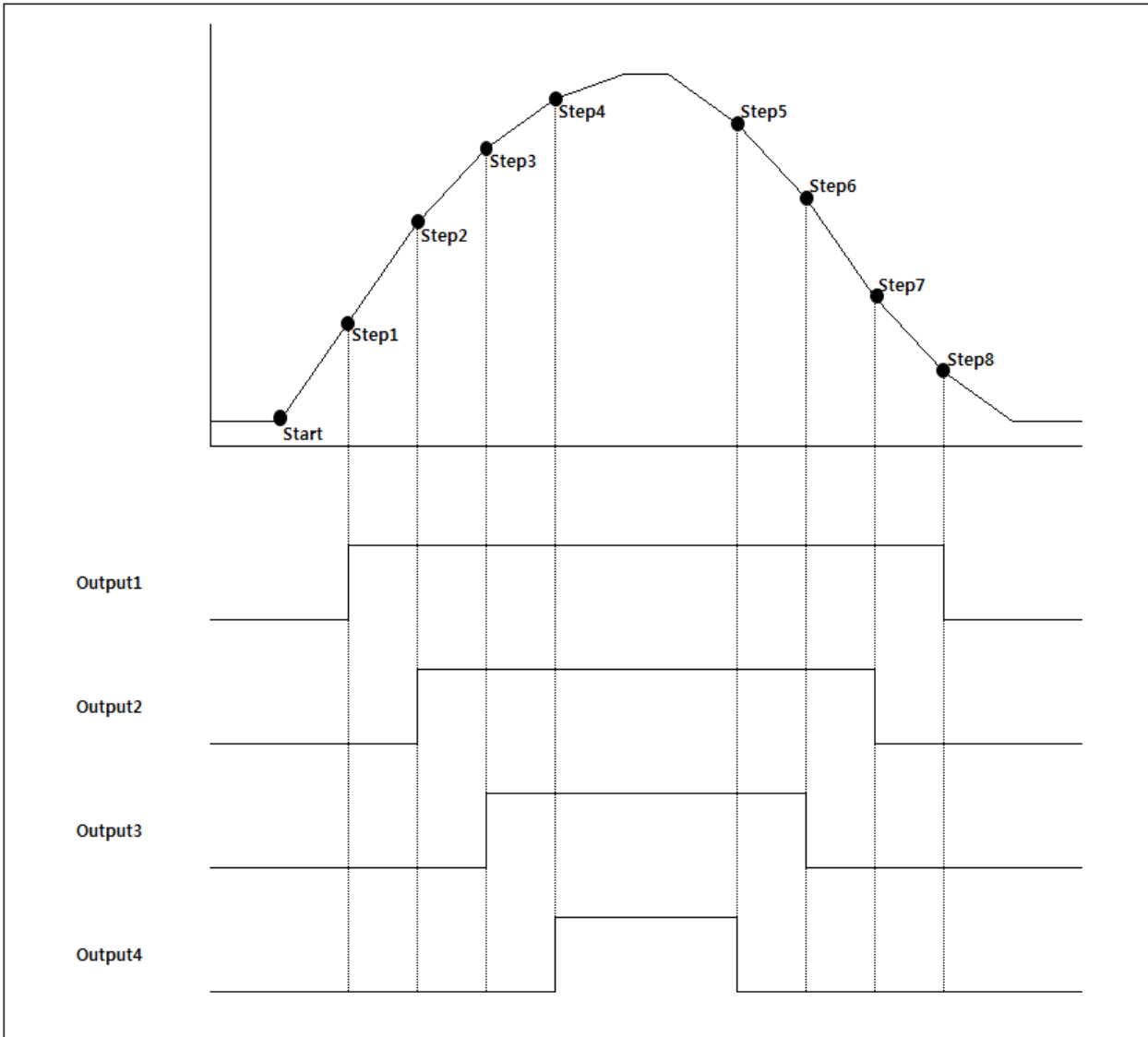

Note 1. Relay is ON, when weight is increasing. Relay is OFF, when weight is decreasing

Weighing Output Information per Mode

Relay Mode	OUT 1	OUT 2	OUT 3	OUT 4
□ 1_Limit Mode	Zero	SP-1 < Weight	SP-2 < Weight	Completed
□ 2_Limit type Checker Mode	Zero	Weight < SP-1	SP-2 < Weight	SP-1 < Weight < SP-2
□ 3_Checker Mode	Zero	Weight < SP-1	SP-2 < Weight	SP-1 < Weight < SP-2
□ 4_Programmable Mode	SP-1 (ON) SP-8 (OFF)	SP-2 (ON) SP-7 (OFF)	SP-3 (ON) SP-6 (OFF)	SP-4 (ON) SP-5 (OFF)

WTM User Manual - Rev.1

Menu-F5.02

Function	Set Ext Input 1	
Set Range (0 ~ 4)	Display Part	Meaning
	5-02. 0	External In1 is zero key
	5-02. 1	External In1 is tare/tareless key
	5-02. 2	External In1 is print key
	5-02. 3	External In1 is hold key
	5-02. 4	External In1 is hold clear key

Menu-F5.03

Function	Set Ext Input 2	
Set Range (0 ~ 4)	Display Part	Meaning
	5-03. 0	External In2 is zero key
	5-03. 1	External In2 is tare/tareless key
	5-03. 2	External In2 is print key
	5-03. 3	External In2 is hold key
	5-03. 4	External In2 is hold clear key

Menu-F5.04

Function	Relay Rerverse On/Off	
Set Range (0 ~ 1)	Display Part	Meaning
	5-04. 0	Relay Reverse OFF
	5-04. 1	Relay Reverse ON

Menu-F5.05

Function	Relay Display On/Off	
Set Range (0 ~ 1)	Display Part	Meaning
	5-05. 0	Relay Display OFF
	5-05. 1	Relay Display ON

6. TCP IP

Menu-F6.01

Function	Set use DHCP	
Set Range (0 ~ 1)	Display Part	Meaning
	6-01. 0	Use DHCP
	6-01. 1	Not use DHCP(Static)

Menu-F6.02

Function	Set TCP mode	
Set Range (0 ~ 1)	Display Part	Meaning
	6-02. 0	Server mode
	6-02. 1	Client mode

Menu-F6.03

Function	Set IP of Server	
Set Range (0 ~ 255)	Display Part	Meaning
	I1-.XXX	Set IP of 1st position(IP_V4)
	I4-.XXX	Set IP of 4th position(IP_V4)

Menu-F6.04

Function	Set Subnet mask	
Set Range (0 ~ 255)	Display Part	Meaning
	M1-.XXX	Set subnet mask of 1st position
	M4-.XXX	Set subnet mask of 4th position

WTM User Manual - Rev.1

Menu-F6.05

Function	Set Gate way	
Set Range (0 ~ 255)	Display Part	Meaning
	G1-.XXX	Set gate way of 1st position
	G4-.XXX	Set gate way of 4th position

Menu-F6.06

Function	TCP port of Server	
Set Range (0 ~ 65535)	Display Part	Meaning
	5000	TCP port nubmer = 5000
	20000	TCP port number = 20000

Menu-F6.07

Function	Server TCP Output mode	
Set Range (0 ~ 8)	Display Part	Meaning
	6-07. 0	Data is not transmitted
	6-07. 1	Transmitted only if the print key is pushed
	6-07. 2	Transmitted in both stable/unstable cases (Stream Mode)
	6-07. 3	Transmitted only if the weight is stable
	6-07. 4	Command Type 1
	6-07. 5	Command Type 2
	6-07. 6	Command Type 3
	6-07. 7	Transmitted only upon completion signal
	6-07. 8	Modbus protocol

Note 1. See Appendices 2, 3, 4 for command types

Note 2. Comm format is followed F2.06 set value

WTM User Manual - Rev.1

Menu-F6.08

Function	Set IP of Client	
Set Range (0 ~ 255)	Display Part	Meaning
	I1-.XXX	Set IP of 1st position(IP_V4)
	I4-.XXX	Set IP of 4th position(IP_V4)

Menu-F6.09

Function	TCP port of Client	
Set Range (0 ~ 65535)	Display Part	Meaning
	5000	TCP port number = 5000
	20000	TCP port number = 20000

Menu-F6.10

Function	Client TCP Output mode	
Set Range (0 ~ 8)	Display Part	Meaning
	6-10. 0	Data is not transmitted
	6-10. 1	Transmitted only if the print key is pushed
	6-10. 2	Transmitted in both stable/unstable cases (Stream Mode)
	6-10. 3	Transmitted only if the weight is stable
	6-10. 4	Command Type 1
	6-10. 5	Command Type 2
	6-10. 6	Command Type 3
	6-10. 7	Transmitted only upon completion signal
	6-10. 8	Modbus protocol

Note 1. See Appendices 2, 3, 4 for command types

Note 2. Comm format is followed F2.06 set value

WTM User Manual - Rev.1

*** 22 Bytes for CAS (Relay status)**

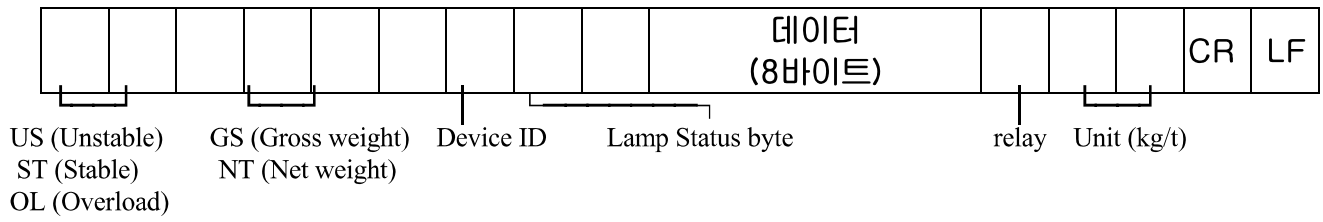

- Relay status bytes

Bt7 Out8	Bt6 Out7	Bt5 Out6	Bt4 Out5	Bt3 Out4	Bt2 Out3	Bt1 Out2	Bt0 Out 1
-------------	-------------	-------------	-------------	-------------	-------------	-------------	--------------

***Weight Date (8 byte)**

Example weight	Byte No							
	1	2	3	4	5	6	7	8
13.5 kg	“	“	“	“	‘1’	‘3’	‘.’	‘5’
135 kg	“	“	“	“	‘1’	‘3’	‘5’	“
-135 kg	‘-’	“	“	“	‘1’	‘3’	‘5’	“

WTM User Manual - Rev.1

Appendix 2> Command Mode 1 Description

CAS <NT-500 Command>

Indicator Reception	Function	Indicator Response
dd RW CR LF	Request for Weight Data	Transmit the data in the set format upon command input
dd MZ CR LF	Same as Zero Key	Execute the zero and retransmit dd MZ CR LF to PC upon command input
dd MT CR LF	Same as Tare Key	Execute tare and retransmit dd MT CR LF to PC upon command input
dd PN 00 CR LF	Input Item No.(00~50)	Change the item no. and retransmit dd PN 00 CR LF to PC upon command input.
dd OP CR LF	Same as Start Key	Execute the start and retransmit dd OP CR LF to PC upon command input
dd EM CR LF	Same as Stop Key	Execute the stop and retransmit dd EM CR LF to PC upon command input

* dd : Device ID. (ASCII Code : 0x30 (hex), 0x31(hex if the Device ID is "01"))

* 00000,00 : Set value for upper limit/lower limit/upper limit fall/lower limit fall
(ASCII Code : 0x30(hex), 0x30(hex), 0x33(hex), 0x34(hex),
0x35(hex) if the set value is "00345")

* When it fails to execute the command : ! CR LF is transmitted to the computer.

* When there is an error in the command : ? CR LF is transmitted to the computer.

WTM User Manual - Rev.1

Appendix 3> Command Mode 2 Description

CAS <NT-570 Command>

Reference 1. Command Mode Table

Command data to NT-570A											Command description	NT-570A Respond	
0	1	2	3	4	5	6	7	8	9	10			11
D	ID	K	Z	CR	LF							ZERO key	
D	ID	K	T	CR	LF							TARE key	Return the received
D	ID	K	G	CR	LF							GROSS key	Return the received
D	ID	K	N	CR	LF							NET key	Return the received
D	ID	K	S	CR	LF							START key	Return the received
D	ID	K	P	CR	LF							STOP key	Return the received
D	ID	K	B	CR	LF							Print key	Return the received
D	ID	K	C	CR	LF							Total print key	Return the received
D	ID	K	W	CR	LF							Request weight data	Return the received
D	ID	H	T	CR	LF							Request set point value	Send Format 2
D	ID	S	1	0	0	0	0	0	CR	LF	1 st Step value	Return the received	
D	ID	S	2	0	0	0	0	0	CR	LF	2nd Step value	Return the received	
D	ID	S	3	0	0	0	0	0	CR	LF	3rd Step value	Return the received	
D	ID	S	4	0	0	0	0	0	CR	LF	4th Step value	Return the received	
D	ID	S	5	0	0	0	0	0	CR	LF	High limit value	Return the received	
D	ID	S	6	0	0	0	0	0	CR	LF	Low limit value	Return the received	
D	ID	H	E	0	0	0	0	0	CR	LF	Set point code(00-99)	Return the received	

(D, ID:00~99, CR : 0×13, LF: 0×10)

*** Format 1 : PC send set point all data to indicator NT-580A**

0	1	2	3	4	5	6	7	8	9	10	11	12	13	14	15	16	17	18	19		
D	ID	H	A	Set Point code						,	SP	SP	SP	SP	SP	SP	SP	„	Optional-		
20	21	22	23	24	25	26	27	28	29	30	31	32	33	34	35	36	37	38	39		
			Preliminary						,	Final value						,	Free Fall				
40	41	42	43	44	45	46	47	48	49	50	51	52	53								
,	High limit					,	Low limit					CR	LF								

*** Format 2 : Recieve the request data from PC then response of Indicator**

0	1	2	3	4	5	6	7	8	9	10	11	12		13	14	15	16	17	18	19	
D	ID	H	T	Set Point 코드						,	SP	SP		SP	SP	SP	SP	„	Optional-		
20	21	22	23	24	25	26	27	28	29	30	31	32		33	34	35	36	37	38	39	
			Preliminary						,	Final value						,	Free Fall				
40	41	42	43	44	45	46	47	48	49	50	51	52		53							
,	High limit					,	Low limit					CR		LF							

* Please input without the decimal point.

WTM User Manual - Rev.1

Appendix 4> Command mode 3 Description

CI-5000 : Transmission only if data is requested (1 byte communication)

Appendix 5> ASCII Table

CHA	CODE	CHA	CODE	CHA	CODE	CHA	CODE	CHA	CODE	CHA	CODE
Space	32	0	48	@	64	P	80		96	p	112
!	33	1	49	A	65	Q	81	a	97	q	113
"	34	2	50	B	66	R	82	b	98	r	114
#	35	3	51	C	67	S	83	c	99	s	115
\$	36	4	52	D	68	T	84	d	100	t	116
%	37	5	53	E	69	U	85	e	101	u	117
&	38	6	54	F	70	V	86	f	102	v	118
'	39	7	55	G	71	W	87	g	103	w	119
(40	8	56	H	72	X	88	h	104	x	120
)	41	9	57	I	73	Y	89	i	105	y	121
*	42	:	58	J	74	Z	90	j	106	z	122
+	43	;	59	K	75	[91	k	107	{	123
,	44	<	60	L	76	\	92	l	108		124
-	45	=	61	M	77]	93	m	109	}	125
.	46	>	62	N	78	^	94	n	110	~	126
/	47	?	63	O	79	_	95	o	111	End	0

Appendix 6> Relay Input

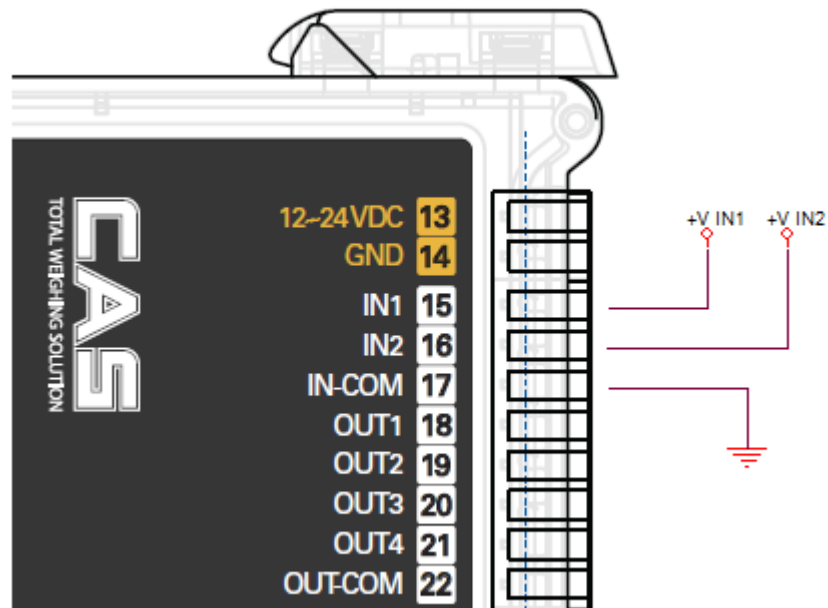

* If 5 to 24 voltage applies to input terminals, a signal inputs to each of terminal.

WTM User Manual - Rev.1

RS485 Communication

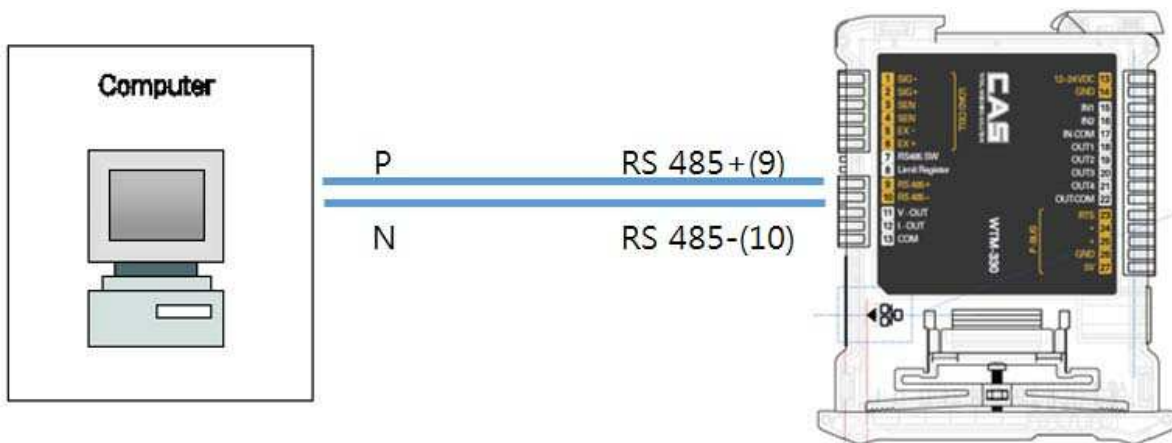

If the RS485 network exceeds 100 meters in length or baud-rate over 9600 are used, on the dip s/w of limit resistance of RS-485 on WTM..It is connect to 120 ohm resistors between the '+' and '-' terminals of RS485 line
Should there be different instrument or converters, refer to the specific manuals to determine whether it is necessary to connect the above-mentioned resistors

Direct connection between RS485 and RS232 without converter

Since a two-wire RS485 output may be used directly on the RS-232 input of a PC or remote display, it is possible to implement instrument connection to an RS-232 port in the following manner.

Instrument		RS232
RS485 -	→	RXD
RS 485 +	→	GND



This type of connection allows A Single instrument to be used in a ONE Way mode.

13 MODBUS-RTU PROTOCOL

The MODBUS-RTU protocol enables to manage the reading and writing of the registers listed here below according to the specifications contained in the reference document for this standard **Modicon PI-MBUS-300**.

To select the communication with MODBUS-RTU, refer to paragraph **SERIAL COMMUNICATION SETTING**

When specifically indicated certain data will be written directly to EEPROM type memories. This memory has a limited number of writing operations (100.000), therefore unnecessary operations at said locations must be avoided. The instrument, in any case, ensures that no writing occurs if the value to be stored is equal to the stored value.

The numerical data listed below are expressed in decimal notation, or hexadecimal notation if preceded by 0x.

MODBUS-RTU DATA FORMAT

The data received and transmitted via MODBUS-RTU protocol have the following characteristics:

- 1 start bit
- 8 data bits, least significant bit sent first
- Instrument settable parity bit
- Instrument settable stop bit

MODBUS SUPPORTED FUNCTIONS

Among the commands available in the MODBUS-RTU protocol, only the following are used to manage communication with the instruments. Other commands may not be interpreted correctly and could generate errors or system shut-downs

FUNCTIONS	DESCRIPTION
03 (0x03)	READ HOLDING REGISTER (PROGRAMMABLE REGISTER READING)
16 (0x10)	PRESET MULTIPLE REGISTERS (MULTIPLE REGISTER WRITING)

The interrogation frequency is linked with the preset communication rate (the instrument will stand by for at least 3 bytes before beginning to calculate a possible response to the query). The Delay parameter present in the paragraph **SERIAL COMMUNICATION SETTING** allows for a further delay in the instrument response, and this directly influences the number of possible queries in the unit of time.

WTM User Manual - Rev.1

For additional information on this protocol, refer to the general technical specification PI_MBUS_300.

In **general**, the query and response to and from a slave instrument are organised as follows:

FUNCTION 3: Read holding registers (PROGRAMMABLE REGISTER READING)

QUERY

Address	Funcion	Register1 Address	No. register	2 bytes
A	0x03	0x0000	0x0002	CRC

Tot. bytes = 8

RESPONSE

Address	Funcion	No.bytes	Register1	Register2	2 bytes
A	0x03	0x04	0x0064	0x00C8	CRC

Tot. bytes = 3 + 2*No. register + 2

where: No. registers= number of Modbus register to be read, starting from the Address 1° register;

No. bytes = number of data bytes to follow;

FUNCTION 16: Preset multiple registers (MULTIPLE REGISTER WRITING)

QUERY

Addr	Func	Add. Reg.1	No.reg.	No. bytes	Val. Reg. 1	Val. Reg. 2	2 bytes
A	0x10	0x0000	0x0002	0x4	0x0000	0x0000	CRC

Tot. bytes = 7 + 2*No. register + 2

RESPONSE

Address	Funcion	Add.Reg.1	No.reg.	2 bytes
A	0x10	0x0000	0x0002	CRC

Tot. bytes = 8

where: No. registers = number of Modbus register to be read, starting from the Address 1° register;

No. bytes = number of data bytes to follow;

Val.reg.1 = register contents beginning from the first.

The Response contains the number of records changed starting from the Address 1° register.

COMMUNICATION ERROR MANAGEMENT

The communication strings are controlled by CRC (Cyclical Redundancy Check). In case of a communication error the slave will not respond with any string. The master must allow for a time-out before response reception. If no response is received it infers that a communication error has occurred.

In the event of a string received correctly but not executable, the slave responds with an EXCEPTIONAL RESPONSE. The "FUNCTION" field is transmitted with the msb at 1.

EXCEPTIONAL RESPONSE

Address	Function	Code	2bytes
A	Funct + 0x80		CRC

CODE	DESCRIPTION
1	ILLEGAL FUNCTION (Function not valid or not supported)
2	ILLEGAL DATA ADDRESS (The specified data address is not available)
3	ILLEGAL DATA VALUE (The data received have no valid value)
4	CRC Error

WTM User Manual - Rev.1

Register List

The MODBUS-RTU protocol implemented on this instrument can manage a maximum of 32 registers read and written in a single query or response.

R = the register can be read only

W = the register can be written only

R/W = the register can be both read and written

H = high half of the DOUBLE WORD forming the number

L = low half of the DOUBLE WORD forming the number

REGISTER	DESCRIPTION	Input value	Saving to EEPROM	ACCESS
40002	Type of instrument	-	-	R
40008	GROSS WEIGHT H	-	-	R
40009	GROSS WEIGHT L	-	-	R
40010	NET WEIGHT H	-	-	R
40011	NET WEIGHT L	-	-	R
40014	Raw AD Data_H	-	-	R
40015	Raw AD Data_L	-	-	R
40017	Set point 1 H	0~99999	Y	R/W
40018	Set point 1 L	0~99999	Y	R/W
40019	Set point 2 H	0~99999	Y	R/W
40020	Set point 2 L	0~99999	Y	R/W
40021	Set point 3 H	0~99999	Y	R/W
40022	Set point 3 L	0~99999	Y	R/W
40023	Set point 4 H	0~99999	Y	R/W
40024	Set point 4 L	0~99999	Y	R/W
40037	Ext_Input	-	-	R/W
40038	Ext_Output	-	-	R/W
40042	Analog out Span Weight H	0~99999	Y	R/W
40043	Analog out Span Weight L	0~99999	Y	R/W
40044	Analog out Zero Adjust H	0~99999	Y	R/W
40045	Analog out Zero Adjust L	0~99999	Y	R/W
40046	Analog out Span Adjust H	0~99999	Y	R/W
40047	Analog out Span Adjust L	0~99999	Y	R/W
40050	Analog Out V-Out range Setting	0~99999		
40051	Analog Out I-Out range Setting	0~99999		
40052	Analog Out Dual-Out range Setting	0~99999		
40060	ADC Speed	0~99999	Y	R/W

WTM User Manual - Rev.1

40062	AD Filter Size	0~99999	Y	R/W
40063	Set Low pass filter	0 : OFF 1 : ON	Y	R/W
40064	Order of Low pass filter	2~4	Y	R/W
40065	Cut frequency of Low pass filter	1~100	Y	R/W
40066	Set Band stop filter	0 : OFF 1 : ON	Y	R/W
40067	High cut Frequency of Band stop filter	1~100	Y	R/W
40068	Low cut Frequency of Band stop filter	1~100	Y	R/W
40069 ~ 40080	Reserved		-	-
40053	Ext_Input		Y	R/W
40060	Ext_Output		Y	R/W
40062	Analog out Span Weight H		Y	R/W
40063	ADC reserved		-	-
40064	ADC reserved		-	-
40065	ADC reserved		-	-
40066	ADC reserved		-	-
40067	ADC reserved		-	-
40068	ADC reserved		-	-
40081	Stable range	0~99	Y	R/W
40082	Zero tracking range	0~9	Y	R/W
40083	Weight back up	0 : OFF 1 : ON	Y	R/W
40084	Zero key range	0~99	Y	R/W
40085	Tare key range	0~99	Y	R/W
40086	Initial zero range	0~99	Y	R/W
40087	Overload range	0~9	Y	R/W
40088	reserved		-	-
40089	Zero, Tare, Gross/Net, Hold, Tare Clear, Hold Clear	1 : Zero 2 : Tare 3 : Gross/Net 4 : Hold 5 : Tare Clear 6 : Hold Clear	Y	W
40090	reserved		-	-
40151	Device Number		Y	R/W
40152	Comm transmit time		Y	R/W
40153	COM1's parity bit		Y	R/W
40154	COM1's Baudrate		Y	R/W
40155	COM1's output data(Gross/Net)		Y	R/W
40156	COM1's output format		Y	R/W
40157	COM1's output mode		Y	R/W
40158 ~	reserved		-	-

WTM User Manual - Rev.1

40170				
40171	Set Year		Y	R/W
40172	Set Month		Y	R/W
40173	Set Date		Y	R/W
40174	Set Hour		Y	R/W
40175	Set Minute		Y	R/W
40176	Set Second		Y	R/W
40177	Set use Alibi memory		Y	R/W
40178 ~ 40199	reserved		-	-
40200	Local IP1 (000. XXX. XXX. XXX)	0~255	Y	R/W
40201	Local IP2 (XXX. 000. XXX. XXX)	0~255	Y	R/W
40202	Local IP3 (XXX. XXX. 000. XXX)	0~255	Y	R/W
40203	Local IP4 (XXX. XXX. XXX. 000)	0~255	Y	R/W
40204	Server IP1 (000. XXX. XXX. XXX)	0~255	Y	R/W
40205	Server IP2 (XXX. 000. XXX. XXX)	0~255	Y	R/W
40206	Server IP3 (XXX. XXX. 000. XXX)	0~255	Y	R/W
40207	Server IP4 (XXX. XXX. XXX. 000)	0~255	Y	R/W
40208	Sub net mask1 (000. XXX. XXX. XXX)	0~255	Y	R/W
40209	Sub net mask2 (XXX. 000. XXX. XXX)	0~255	Y	R/W
40210	Sub net mask3 (XXX. XXX. 000. XXX)	0~255	Y	R/W
40211	Sub net mask4 (XXX. XXX. XXX. 000)	0~255	Y	R/W
40212	Gate way1 (000. XXX. XXX. XXX)	0~255	Y	R/W
40213	Gate way2 (XXX. 000. XXX. XXX)	0~255	Y	R/W
40214	Gate way3 (XXX. XXX. 000. XXX)	0~255	Y	R/W
40215	Gate way4 (XXX. XXX. XXX. 000)	0~255	Y	R/W
40216	Set DHCP	0 : OFF 1: ON	Y	R/W
40217	Set TCP/IP Mode (Server mode, Client mode)	0 : Server 1: Client	Y	R/W
40218	Set Local Port Number	0~65535	Y	R/W
40219	Set Server Port Number	0~65535	Y	R/W
40220	Set Local Comm mode	0~7	Y	R/W
40221	Set Server Comm mode	0~7	Y	R/W

14 Error Message

1. Error Message from the Weight Setup Mode

Error	Cause	Solution
Err 20	The resolution was set in excess of the tolerance 1/10,000.	Lower the resolution. As the resolution = maximum tolerance / value of one division, adjust the resolution to 1/10,000 or less by correcting either the maximum allowable weight in CAL 1 or the value of one division in CAL3 in the weight setup mode.
Err 21	The resolution was set in excess of the tolerance 1/30,000.	Lower the resolution. As the resolution = maximum tolerance / value of one division, adjust the resolution to 1/30,000 or less by correcting either the maximum allowable weight in CAL 1 or the value of one division in CAL3 in the weight setup mode.
Err 22	The weight for the span adjustment was set to less than 10% of the maximum capacity.	Set the weight to 10% or more of the maximum capacity (set in CAL 1) from CAL 4 in the weight setup mode.
Err 23	The weight for the span adjustment was set to more than 100% of the maximum capacity.	Set the weight within the maximum capacity (set in CAL 1) from CAL 4 in the weight setup mode.
Err 24	Too low span.	Set the weight again by lowering the resolution as the setting of the current resolution is not possible because of either abnormality or lower output in the load cell. Two low weight for PCS and percent sample.
Err 25	Too high span.	There is either any abnormality or too high output in the load cell. Execute steps from the zeroing step in CAL 4 in the weight set up again. Two high weight for PCS and percent sample.
Err 26	Too high zero point.	Check whether or not the load tray is empty. Retry the weight setup after check at the test mode 3.
Err 27	Too low zero point.	Set the weight setting again after confirming what force is given to the load tray of the scale in the test mode 3.
Err 28	Weight is shaking.	Check the connection of the load cell connector.

WTM User Manual - Rev.1

2. Error Message from the Weighing Mode

Error	Cause	Solution
Err 01	The initialization of the scale cannot be done because of the shaking weight.	Turn on the power after placing the scale at a flat place with no vibration.
Err 02	Either the connection of load cell is wrong or there is abnormality in the A/D conversion section.	Check the connection between the load tray and the body.
Err 08	The zero key, tare key and start key were disabled at the instable weight.	Set the zero key, tare key and start key to the proper user conditions at F14 in the Set Mode.
Err 09	The current weight is out of the range of zero point.	Set the range of operations for the zero key to within 2% or 10% at F13 in the Set Mode.
Err 10	The tare to set is out of the maximum weight of the scale.	Set the tare to less than the maximum weight.
Err 12	The type of the configured printer is one that cannot support the total print.	DLP printers cannot make the total print. Set "F40" to '2' when DEP printers are used.
Err 13	The set value of zero point on the weight setting is out of range.	Check the status of the load tray and set the weight again.
Err 15	The range exceeded during setting the item code in the command mode.	Check the range of item code.
999999	The current weight on the load tray is too heavy and out of the allowable tolerance.	Avoid any weight in excess of the maximum allowable limit on the scale. If the load cell is damaged, it should be replaced.
Err 01	The initialization of the scale cannot be done because of the shaking weight.	Turn on the power after placing the scale at a flat place with no vibration.