

# DSB-20

## Truck and Tank Weighing Load Cell

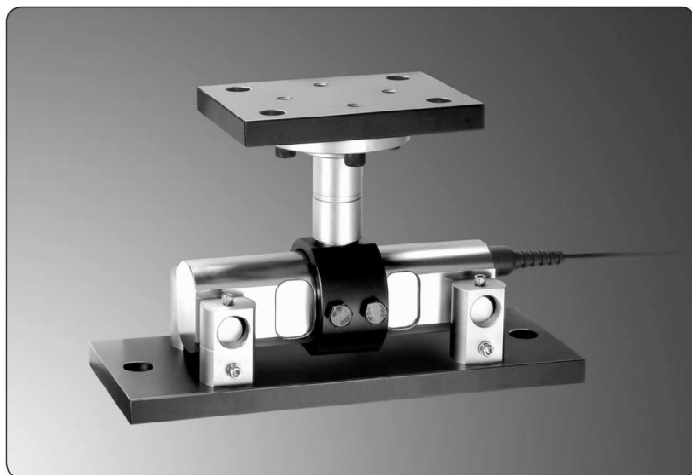

### LOAD CELL



### DIMENSION

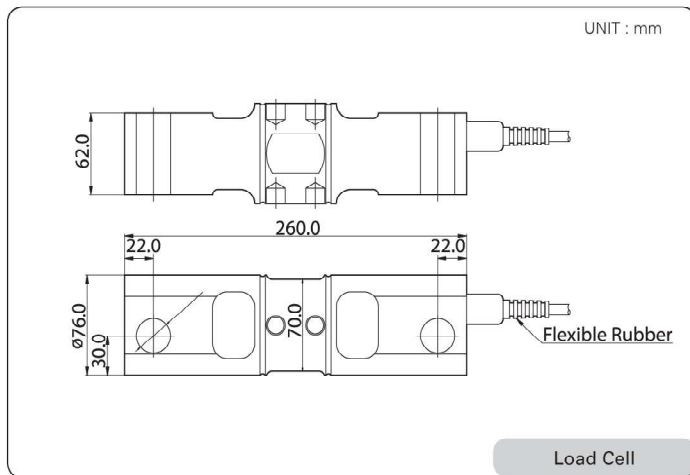

### FEATURES

- Nickel plated steel construction
- Rocker pin loading design
- Truck scale Load Cell with accessory
- Designed according to IP67

### ACCESSORY FEATURES

- Appropriate for tank and hopper application
- Designed for safety
- High resistance against side force
- High durability

### ACCESSORY OPTION

- Accessory (Set)

### MANUAL

- Check the Load Cell level with the surface

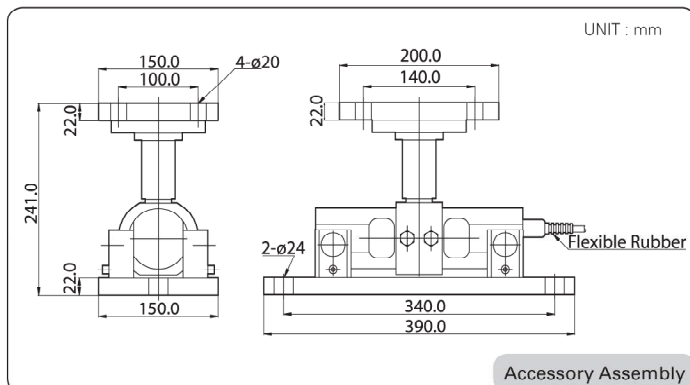

### SPECIFICATION

Capacity		tf	20
Rated Output		mV / V	2.0 ± 0.004
Zero Balance		mV / V	0.0 ± 0.02
Accuracy Class		-	-
Non-Linearity		% R.O.	≤ 0.03
Hysteresis		% R.O.	≤ 0.03
Combined Error		% R.O.	≤ 0.03
Repeatability		% R.O.	≤ 0.01
Creep for 30min.		% R.O.	≤ 0.03
Return for 30min.		% R.O.	≤ 0.03
Resolution		-	≤ 1/3000
Division		mV / V	0.00067
Temperature Effect on	-Zero Value	%/10°C	≤ 0.03
	-Output Value	%/10°C	≤ 0.015
Excitation	-Recommended	V	10
	-Maximum	V	15
Resistance	-Input	Ω	800 ± 40
	-Output	Ω	700 ± 7
	-Insulation	MΩ	> 2000
Compensated Temperature Range		°C	- 10 to + 40
Operating Temperature Range		°C	- 20 to + 80
Material & Plate		-	Nickel plated steel
Cable Specification		-	ø8 x 4P x 15M (P.V.C)
Safety Overload		% R.L.	150% R.L.
Platform Size		mm	No Platform type