

吊钩秤、配料秤、包装秤、机电结合秤及专用测力装置
Crane scale, blending scale, packing scale, electromechanical scale, special testing device

额定载荷	A	B	C	D
20~150kg	70	64	12	M8
200~500kg	70	64	20	M12
700~1000kg	70	64	25	M12
1.5~5t	88	90	32	M20
7.5t	88	90	40	M24

TECHNICAL PARAMETER

4Wires:Exc+(红,Red);Exc-(黑,Black);Sig+(绿,Green);Sig-(白,White)

额定载荷 Rated load	20,30,50,75,100,150,200,250,300,500,700,750kg,1t,1.5t,2t,3t,5t,7.5t	绝缘电阻 Insulation resistance	≥5000 MΩ
精度等级 Accuracy class	0.03	额定温度 Nominal Temp Range	-10~+40℃
灵敏度 Sensitivity	2.0 ± 0.003mV/V	工作温度范围 Service Temp Range	-30~+70℃
线性误差 Non-linearity	± 0.03%F.S	安全负载 Safe load limit	150%F.S
滞后误差 Hysteresis error	± 0.03%F.S	破坏负载 Breaking load	200%F.S
蠕变 (30分钟) Creep(30min)	± 0.03%F.S	额定激励电压 Nominal of range excitation	10~12 V DC
零点温度影响 TC ZERO	± 0.02%F.S/10℃	密封等级 Protection Class	IP66(20kg~1t),IP68(1.5t~7.5t)
灵敏度温度影响 TC SPAN	± 0.02%F.S/10℃	材料 Material	合金钢 Alloy Steel
输入阻抗 Input resistance	400 ± 20Ω (1.5t~7.5t)		不锈钢 Stainless Steel
输出阻抗 Output resistance	352 ± 5Ω	电缆 Cable	Length=2.6m(20kg~1t), 3m(1.5~7.5t)

20kg~1t

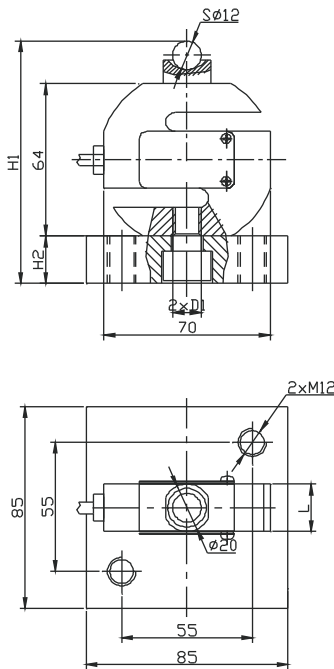

额定载荷 Rated Load	H1	H2	D1	L
20~150kg	97	15	M8	12
200~500kg	103	19	M12	20
700~1000kg	103	19	M12	25

2t~7.5t

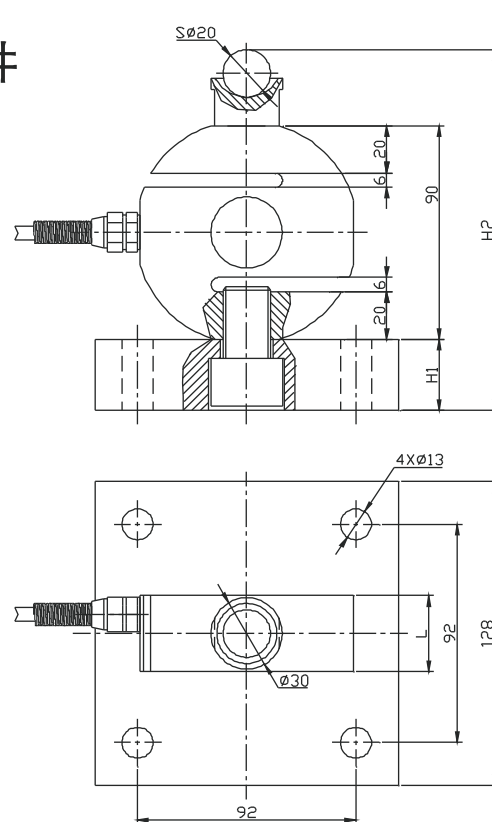

额定载荷 Rated Load	H1	H2	L
2~5t	29	151	32
7.5t	34	156	40

总装B附件

总装D附件

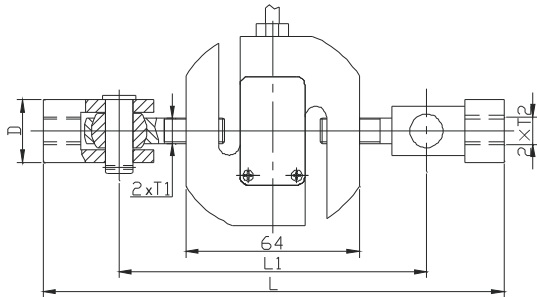

额定载荷 Rated Load	L,max	L1,max	T1	T2	D
20~150kg	184	124	M8	M8	24
200~500kg	228	148	M12	M12	34
700~1000kg	228	148	M12	M12	34
2t~5t	326	206	M20	M24	56

总装E附件

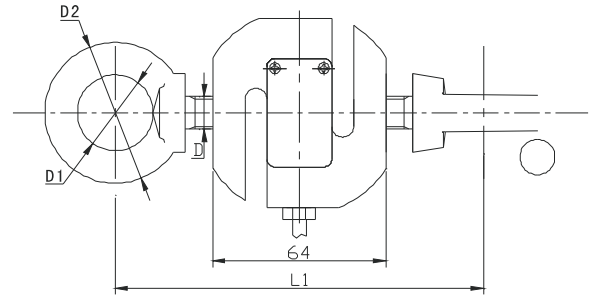

额定载荷 Rated Load	D	D1	D2	L1,max	L2
20~150kg	M8	20	36	108	9
200~300kg	M12	28	52	136	13