

配料控制系统、平台秤
Blending control system, low platform scale

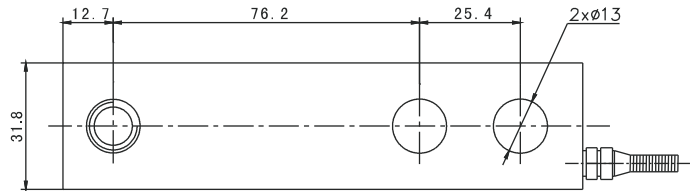

TECHNICAL PARAMETER

4Wires:Exc+(红,Red);Exc-(黑,Black);Sig+(绿,Green);Sig-(白,White)

额定载荷 Rated load	0.1、0.15、0.2、0.25、0.3、0.5、0.75、1、1.5、2、2.5t	输出阻抗 Output resistance	352 ± 3 Ω
精度等级 Accuracy class	C2~C3	绝缘电阻 Insulation resistance	≥ 5000 MΩ
灵敏度 Sensitivity	0.1~0.3t: 2.0 ± 0.002mV/V 0.5~2.5t: 3.0 ± 0.003mV/V	额定温度 Nominal Temp Range	-10~+40℃
线性误差 Non-linearity	± 0.03%F.S	工作温度范围 Service Temp Range	-30~+70℃
滞后误差 Hysteresis error	± 0.03%F.S	安全负载 Safe load limit	150%F.S
蠕变 (30分钟) Creep(30min)	± 0.02%F.S	破坏负载 Breaking load	200%F.S
零点温度影响 TC ZERO	± 0.02%F.S/10℃	额定激励电压 Nominal of range excitation	10~12 V DC
灵敏度温度影响 TC SPAN	± 0.02%F.S/10℃	密封等级 Protection Class	IP67(0.1~0.75t) IP68(1~2.5t)
输入阻抗 Input resistance	400 ± 20 Ω	材料 Material	合金钢 Alloy Steel
		电缆 Cable	Length:1.5m:3m 比例1:1

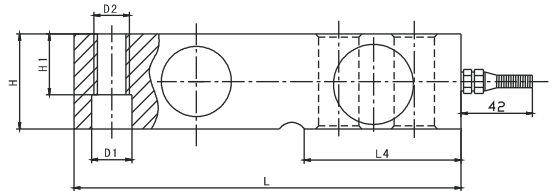

额定载荷(t) Rated Load	L	L1	L2	L3	L4	H/B	H1	D1	D2	D3
3.5	171.5	19	95.3	38.1	72.5	38.1	26	φ20	M18x1.5	φ20
7.5~10	225.5	25.3	124	50.8	102	50.8	25.4	φ27	M24x2	φ27

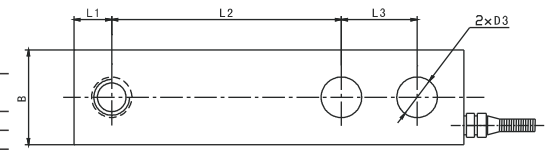

平台秤、配料控制系统
Platform scales, blending scale

TECHNICAL PARAMETER

4Wires:Exc+(红,Red);Exc-(黑,Black);Sig+(绿,Green);Sig-(白,White)

额定载荷 Rated load	3、5、7.5、10t	绝缘电阻 Insulation resistance	≥ 5000 MΩ
精度等级 Accuracy class	0.03	额定温度 Nominal Temp Range	-10~+40℃
灵敏度 Sensitivity	3.0 ± 0.003mV/V	工作温度范围 Service Temp Range	-30~+70℃
线性误差 Non-linearity	± 0.03%F.S	安全负载 Safe load limit	150%F.S
滞后误差 Hysteresis error	± 0.03%F.S	破坏负载 Breaking load	200%F.S
蠕变 (30分钟) Creep(30min)	± 0.02%F.S	额定激励电压 Nominal of range excitation	10~12 V DC
零点温度影响 TC ZERO	± 0.02%F.S/10℃	密封等级 Protection Class	IP68
灵敏度温度影响 TC SPAN	± 0.02%F.S/10℃	材料 Material	合金钢 Alloy Steel
输入阻抗 Input resistance	400 ± 20 Ω	电缆 Cable	Length:4.2m (3t~5t)
输出阻抗 Output resistance	352 ± 3 Ω		5m(7.5t~10t)

SQB Bottom Components/Weighing Module

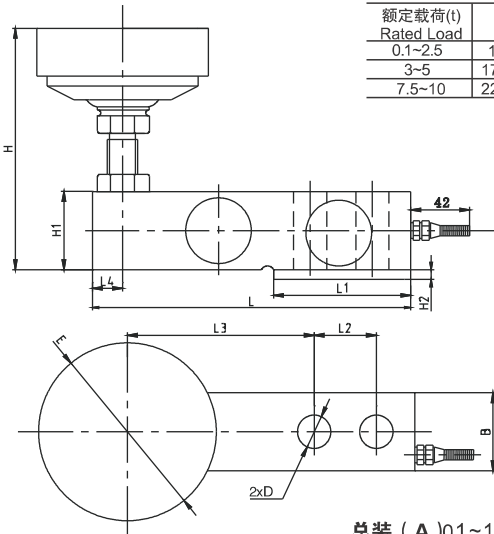

总装 (A) 0.1~10t活动压头附件

Installation A :feet

额定载荷(t) Rated Load	L	L1	L2	L3	L4	B	H	H1	H2	D	E
0.1~2.5	130	53.5	25.4	76.2	12.7	31.8	85-90	31.8	4	φ13	φ62
3~5	171.5	72.5	38.1	95.3	19	38.1	104-114	38.1	6	φ20	φ62
7.5~10	225.5	102	50.8	124	25.3	50.8	132-144	50.8	8	φ27	φ80

额定载荷(t) Rated Load	L	L1	L2	L3	L4	B	H	H1	H2	H3	D	D1	D2	D3
0.1~2.5	130	53.5	25.4	76.2	12.7	31.8	77.8	31.8	12	4	φ13	φ38	φ12	S φ16
3~5	171.5	72.5	38.1	95.3	19	38.1	94.1	38.1	10	6	φ20	φ50	φ16	S φ20
7.5~10	225.5	102	50.8	124	25.3	50.8	130	50.8	10	8	φ27	φ64	φ20	S φ32

总装 (B) 0.1~10t钢球压头附件 Installation B :feet

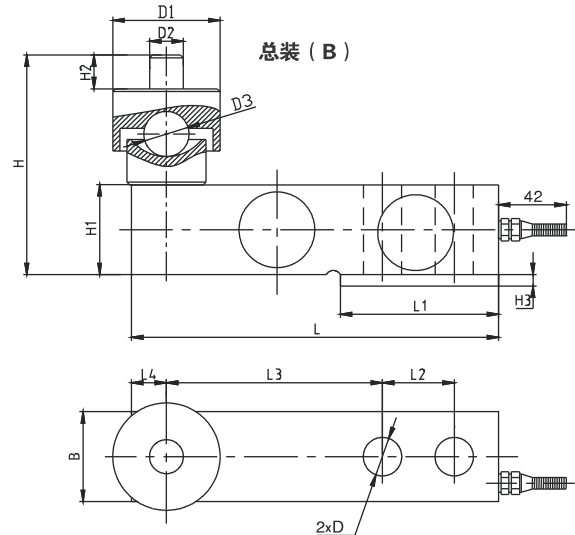

总装 (B)

总装 (D) 称重模块
Installation(D) weighing module

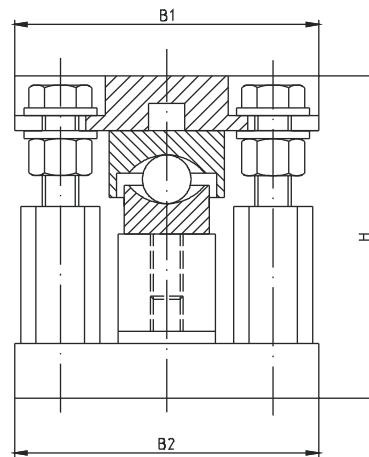
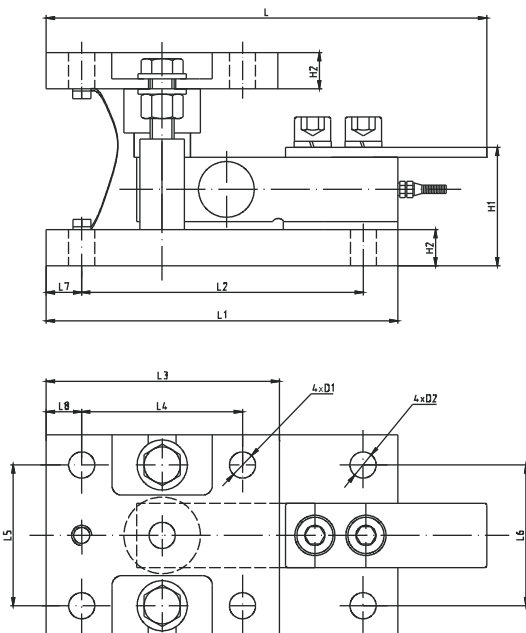

额定载荷(t) Rated Load	H	H1	H2	B1	B2	D1	D2	L	L1	L2	L3	L4	L5	L6	L7	L8
0.1~2.5	106	58	18	100	100	φ13	φ13	210	175	140	116	80	70	70	17.5	18
3~5	135	69.1	23	150	150	φ17	φ17	270	235	200	150	100	90	90	15	25
7.5~10	186.3	91.3	30.2	180	180	φ26	φ26	345.2	310	250	210.4	150.4	110	110	30	30

0.1~5t称重模块
Weighing module installation

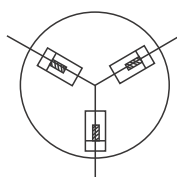

径向安装Radial mounting

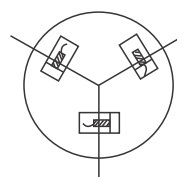

切向安装Cutting mounting

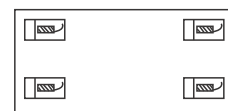

矩形安装Rectang mounting